

DOCUMENTATION

PUMP 10C50 GT

AIRMIX[®]

Manual : 582.043.110-UK - 1904

Date: 30/04/19

Supersede : 27/05/16

Modif.:

TRANSLATION FROM THE ORIGINAL MANUAL

IMPORTANT : Before assembly and start-up, please read and clearly understand all the documents relating to this equipment (professional use only).

THE PICTURES AND DRAWINGS ARE NON CONTRACTUAL. WE RESERVE THE RIGHT TO MAKE CHANGES WITHOUT PRIOR NOTICE..

SAMES KREMLIN SAS

13, chemin de Malacher
38 240 - MEYLAN - France
 : 33 (0)4 76 41 60 60

www.sames-kremlin.com



<p align="center">FR</p> <p>Pour une utilisation sûre, il est de votre responsabilité de :</p> <ul style="list-style-type: none"> • Lire attentivement tous les documents contenus dans le CD joint avant la mise en service de l'équipement, • D'installer, d'utiliser, d'entretenir et de réparer l'équipement conformément aux préconisations de SAMES KREMLIN ainsi qu'aux réglementations nationales et/ou locales, • Vous assurez que les utilisateurs de cet équipement ont été formés, ont parfaitement compris les règles de sécurité et qu'ils les appliquent. 	<p align="center">UK</p> <p>To ensure safe use of the machinery, it is your responsibility to:</p> <ul style="list-style-type: none"> • Carefully read all documents contained on the enclosed CD before putting the machinery into service, • Install, use, maintain and repair the machinery in accordance with SAMES KREMLIN's recommendations and national and/or local regulations, • Make sure that the users of the machinery have received proper training and that they have perfectly understood the safety rules and apply them. 	<p align="center">DE</p> <p>Eine sichere Nutzung setzt voraus, dass Sie :</p> <ul style="list-style-type: none"> • alle in der CD enthaltenen Dokumente vor der Inbetriebnahme der Anlage aufmerksam lesen, • die Anlage im Einklang mit den Empfehlungen von SAMES KREMLIN sowie mit den nationalen und/oder lokalen Bestimmungen installieren, verwenden, warten und reparieren, • sich vergewissern, dass die Nutzer dieser Anlage angemessen geschult wurden, die Sicherheitsbestimmungen verstanden haben und sie anwenden.
<p align="center">ES</p> <p>Para una utilización segura, será de su responsabilidad:</p> <ul style="list-style-type: none"> • leer atentamente todos los documentos que se incluyen en el CD adjunto antes de la puesta en servicio del equipo, • instalar, utilizar, efectuar el mantenimiento y reparar el equipo con arreglo a las recomendaciones de SAMES KREMLIN y a la normativa nacional y/o local, • cerciorarse de que los usuarios de este equipo han recibido la formación necesaria, han entendido perfectamente las normas de seguridad y las aplican. 	<p align="center">IT</p> <p>Per un uso sicuro, vi invitiamo a:</p> <ul style="list-style-type: none"> • leggere attentamente tutta la documentazione contenuta nel CD allegato prima della messa in funzione dell'apparecchio, • installare, utilizzare, mantenere e riparare l'apparecchio rispettando le raccomandazioni di SAMES KREMLIN, nonché le normative nazionali e/o locali, • accertarvi che gli utilizzatori dell'apparecchio abbiano ricevuto adeguata formazione, abbiano perfettamente compreso le regole di sicurezza e le applichino. 	<p align="center">PT</p> <p>Para uma utilização segura, é da sua responsabilidade:</p> <ul style="list-style-type: none"> • Ler atentamente todos os documentos incluídos no CD em anexo antes de pôr o equipamento em funcionamento, • Proceder à instalação, utilização, manutenção e reparação do equipamento de acordo com as preconizações de SAMES KREMLIN, bem como com outros regulamentos nacionais e/ou locais aplicáveis, • Assegurar-se que os utilizadores do equipamento foram devidamente capacitados, compreenderam perfeitamente e aplicam as devidas regras de segurança.
<p align="center">NL</p> <p>Voor een veilig gebruik dient u:</p> <ul style="list-style-type: none"> • alle document op de bijgevoegde cd aandachtig te lezen alvorens het apparaat in werking te stellen, • het apparaat te installeren, gebruiken, onderhouden en repareren volgens de door SAMES KREMLIN gegeven aanbevelingen en overeenkomstig de nationale en/of plaatselijke reglementeringen, • zeker te stellen dat de gebruikers van dit apparaat zijn opgeleid, de veiligheidsregels perfect hebben begrepen en dat zij die ook toepassen. 	<p align="center">SE</p> <p>För en säker användning av utrustningen ansvarar ni för följande:</p> <ul style="list-style-type: none"> • Läs noga samtliga dokument som finns på den medföljande cd-skivan innan utrustningen tas i drift. • Installera, använd, underhåll och reparera utrustningen enligt anvisningarna från SAMES KREMLIN och enligt nationella och/eller lokala bestämmelser. • Försäkra er om att användare av denna utrustning erhållit utbildning, till fullo förstått säkerhetsföreskrifterna och tillämpar dem. 	<p align="center">FI</p> <p>Käytön turvallisuuden varmistamiseksi velvollisuutesi on:</p> <ul style="list-style-type: none"> • Lukea huolella kaikki CD:llä olevat asiakirjat ennen laitteiston käyttöönottoa, • Noudattaa laitteiston asennuksessa, käytössä, kunnossapidossa ja huollossa SAMES KREMLIN in suosituksia sekä kansallisia ja/tai paikallisia määräyksiä, • Varmistaa, että laitteiston käyttäjät ovat koulutettuja ja ymmärtävät täysin turvallisuusmääräykset ja miten niitä sovelletaan.
<p align="center">PL</p> <p>Dla zapewnienia bezpiecznego użytkowania na użytkownika spoczywa obowiązek:</p> <ul style="list-style-type: none"> • Uważnego zapoznania się ze wszystkimi dokumentami znajdującymi się na załączonej płycie CD przed pierwszym uruchomieniem urządzenia, • Instalowania, użytkowania, konserwacji i naprawy urządzenia zgodnie z zaleceniami firmy SAMES KREMLIN oraz z przepisami miejscowymi, • Upewnienia, że wszyscy przeszkoleni użytkownicy urządzenia zrozumieli zasady bezpieczeństwa i stosują się do nich. 	<p align="center">CS</p> <p>Pro bezpečné používání jste povinni:</p> <ul style="list-style-type: none"> • Před uvedením zařízení do provozu si pozorně přečíst veškeré dokumenty obsažené na příloženém CD, • Nainstalovat, používat, udržovat a opravovat zařízení v souladu s pokyny firmy SAMES KREMLIN a s národními a/nebo místními legislativními předpisy, • Ujistit se, že uživatelé tohoto zařízení byli vyškoleni, že dokonale pochopili bezpečnostní pravidla a že je dodržují. 	<p align="center">SL</p> <p>Za varno uporabo ste dolžni:</p> <ul style="list-style-type: none"> • natančno prebrati vse dokumente na CD pred zagonom stroja, • instalirati, uporabljati, vzdrževati in popravljati opremo po določilih SAMES KREMLIN in v skladu z veljavnimi nacionalnimi in/ali lokalnimi predpisi, • poskrbeti, da so uporabniki te opreme ustrezno usposobljeni, poznajo varnostne predpise in da jih upoštevajo.
<p align="center">SK</p> <p>V záujme bezpečného je vašou povinnosťou:</p> <ul style="list-style-type: none"> • pozorne si prečítať všetky dokumenty obsiahnuté na priloženom CD predtým, ako zariadenie uvediete do prevádzky, • nainštalovať, používať, udržiavať a opravovať zariadenie v súlade s odporúčaniami spoločnosti SAMES KREMLIN a národnými a/alebo miestnymi predpismi, • uistiť sa, že používatelia tohto zariadenia boli zaškolení, riadne porozumeli pravidlám bezpečnosti a používajú ich. 	<p align="center">HU</p> <p>A biztonságos használat érdekében az Ön felelőssége, hogy:</p> <ul style="list-style-type: none"> • a berendezés üzembe helyezése előtt figyelmesen elolvassa a mellékelt CD által tartalmazott összes dokumentumot, • a berendezést a SAMES KREMLIN ajánlásainak valamint a nemzeti és/vagy helyi szabályozásoknak megfelelően helyezze üzembe, használja, tartsa karban és javítsa, • megbizonyosodjon róla, hogy a berendezés felhasználói képzettek, tökéletesen megértették és alkalmazzák a biztonsági előírásokat. 	<p align="center">RO</p> <p>Pentru o utilizare sigură, este responsabilitatea dvs. să:</p> <ul style="list-style-type: none"> • Citiți cu atenție toate documentele de pe CD-ul anexat, înainte de punerea în funcțiune a echipamentului, • Instalați, utilizați, întrețineți și reparați echipamentul conform instrucțiunilor SAMES KREMLIN precum și reglementărilor naționale și/sau locale, • Vă asigurați că utilizatorii acestei echipament au fost instruiți, au înțeles perfect regulile de securitate și le aplică integral.

Declaration(s) de conformité au verso de ce document / Declaration(s) of conformity at the back of this document / Konformitätserklärung(en) auf der Rückseite dieser Unterlage / Declaración (es) de conformidad en el reverso de este documento / Dichiarazione/i di conformità sul retro del presente documento / Declaração(ões) de conformidade no verso do documento / Conformiteitsverklaring(en) op de keerzijde van dit document / Försäkran om överensstämmelse på omstående sida av detta dokument / Vaatimustenmukaisuusvakuutukset tämän asiakirjan kääntöpuolella / Deklaracja(e) zgodności na odwrocie dokumentu / Prohlášení o shodě se nachází/nacházejí na zadní straně tohoto dokumentu / Deklaracija(e) o skladnosti na hrbtni strani tega dokumenta / Vyhlasenie/-a o zhode sa nachádzajú na zadnej strane dokumentu / A dokumentum hátlapján szereplő megfelelőségi nyilatkoz(ok) / Declarații de conformitate pe versoul acestui document



DECLARATION UE DE CONFORMITE
EU DECLARATION OF CONFORMITY
EU- KONFORMITÄTSEKTLÄRUNG
DECLARACIÓN UE DE CONFORMIDAD
DICHIARAZIONE DI CONFORMITÀ UE
DECLARAÇÃO UE DE CONFORMIDADE
EU-KONFORMITEITSVERKLARING
EU-FÖRSÄKRAN OM ÖVERENSSTÄMMELSE
EU- VAATIMUKSEN MUKAISUUSVAKUUTUS
DEKLARACJA ZGODNOŚCI UE
EU PROHLÁŠENÍ O SHODĚ
IZJAVA EU O SKLADNOSTI
VYHLÁSENIE O ZHODE
EU-MEGFELELŐSÉGI NYILATKOZAT
DECLARAȚIA DE CONFORMITATE UE

Le fabricant / The manufacturer / Der Hersteller / El fabricante / Il produttore / O fabricante / De fabrikant / Tillverkare / Valmistaja / Producent / Výrobce / Proizvajalec / Výrobca / Gyártó / Fabricantul:	SAMES KREMLIN SAS 13, chemin de Malacher 38 240 - MEYLAN - FRANCE Tél. : 33 (0)4 76 41 60 60
---	--

Déclare que le matériel désigné ci-après / Herewith declares that the equipment / erklårt hiermit, dass die / Declara que el material designado a continuación / Dichiaro che il materiale sottoindicato / Declara que o material a seguir designado / verklaart dat de hieronder aangeduide apparatuur / Kungör att den utrustning som anges här nedan / ilmoittaa, että alla mainitut laitteistot / Oświadczam, że wymienione poniżej urządzenia / Prohlašuje, že níže uvedené vybavení / Izjavlja, da je opisana oprema spodaj / Vyhlasuje, že zariadenie uvedené nižšie / Kijelenti, hogy a megjelölt anyag a továbbiakban / Declară că echipamentul precizat mai jos:

POMPE INTENSIVE™ BASSE ET MOYENNE PRESSION POUR APPLICATION PNEUMATIQUE ET AIRMIX®
A MOTEUR AVEC INVERSEUR / INTENSIVE™ AIRMIX® & LOW PRESSURE PUMP - AIR MOTOR WITH
REVERSING BLOCK / INTENSIVE™ AIRMIX® PNEUMATISCHE PUMPE MIT UMSTEUERMOTOR
/ BOMBA NEUMÁTICA INTENSIVE™ Y BOMBA AIRMIX® INTENSIVE™ CON MOTOR CON INVERSOR

10C50 GT

Est conforme à la législation d'harmonisation de l'Union applicable suivante / Is in conformity with the relevant Union harmonisation legislation / Erfüllt die einschlägigen Harmonisierungsrechtsvorschriften der Union / es conforme con la legislación de armonización pertinente de la Unión / è conforme alla pertinente normativa di armonizzazione dell'Unione / in overeenstemming met de desbetteffende harmonisatiewetgeving van de Unie / med den relevanta harmoniserade unionslagstiftningen / on asiaa koskevan unionin yhdenmukaistamislainsäädännön vaatimusten mukainen / jest zgodny z jednostronnymi wymaganiami unijnego prawodawstwa harmonizacyjnego / Shoduje se s následující příslušnou evropskou harmonizační legislativou / V skladu s harmonizirano zakonodajo Unije / Je v súlade s uplatniteľnými harmonizačnými právnymi predpismi EÚ / Megfelel a következő alkalmazandó uniós harmonizációs szabályozásnak / Este conform cu legislația aplicabilă de armonizare de mai jos

Directive ATEX / ATEX Directive / ATEX Richtlinie / Directiva ATEX / Direttiva ATEX / Diretiva ATEX / ATEX-Richtlijn / ATEX-direktivet / ATEX-direktivi / Dyrektywa ATEX / Směrnice ATEX / Direktiva ATEX / Smernica ATEX / ATEX-irányelv	 II 2G h T3	2014/34/UE
---	--	-------------------

EN 80079-36

La présente déclaration de conformité est établie sous la seule responsabilité du fabricant / This declaration of conformity is issued under the sole responsibility of the manufacturer / Die alleinige Verantwortung für die Ausstellung dieser Konformitätserklärung trägt der Hersteller / La presente declaración de conformidad se expide bajo la exclusiva responsabilidad del fabricante / La presente dichiarazione di conformità è rilasciata sotto la responsabilità esclusiva del fabbricante / A presente declaração de conformidade é emitida sob a exclusiva responsabilidade do fabricante / Deze conformiteitsverklaring wordt verstrekt onder volledige verantwoordelijkheid van de fabrikant / Denna försäkran om överensstämmelse utfärdas på tillverkarens eget ansvar / Tämä vaatimustenmukaisuusvakuutus on annettu valmistajan yksinomaisella vastuulla / Niniejsza deklaracja zgodności wydana zostaje na wyłączną odpowiedzialność producenta / Toto prohlášení o skodě se vydává na výhradní odpovědnost výrobce / Za izdajo te izjave o skladnosti je odgovoren izključno proizvajalec / Toto vyhlásenie o zhode sa vydáva / na vlastnú zodpovednosť výrobcu / Ezt a megfelelőségi nyilatkozatot a gyártó kizárólagos felelőssége mellett adják ti / Prezenta declarație de conformitate este emisă pe răspunderea exclusivă a producătorului.



Hervé WALTER

Directeur Innovation & Développement / Innovation & Development Director / Direktor für Innovation & Entwicklung / Director de Innovación y Desarrollo / Direttore Innovazione e sviluppo / Diretor de Inovação / Manager Innovatie en Ontwikkeling / Direktör för Forskning och Utveckling / Innovaatio- ja kehitysjohtaja / Dyrektor ds. Innowacji i Rozwoju / Ředitel pro inovace a vývoj / Direktor za inovacije in razvoj / Riaditeľ pre inováciu a rozvoj / Innovációs és fejlesztési igazgató / Director Inovație și Dezvoltare

Fait à Meylan, le / Established in Meylan, on / Geschehen zu Meylan, am / En Meylan, a / Redatto a Meylan, / Vastgesteld te Meylan, / Utformat i Meylan, den / Meylan, Ranska, / Sporządzono w Meylan, dnia / Meylan, dnia / V Meylanu, / V Meylan dňa / Kelt Meylanban, / Întocmită la Meylan, pe data de 12/04/2019 - 04/12/2019



INSTALLATION AND SAFETY INSTRUCTIONS

TRANSLATION FROM THE ORIGINAL MANUAL

IMPORTANT : Before assembly and start-up, please read and clearly understand all the documents relating to this equipment (professional use only).

THE PICTURES AND DRAWINGS ARE NON CONTRACTUAL. WE RESERVE THE RIGHT TO MAKE CHANGES WITHOUT PRIOR NOTICE.

SAMES KREMLIN SAS
13, chemin de Malacher
38 240 - MEYLAN - France
☎ : 33 (0)4 76 41 60 60

www.sames-kremlin.com

1. SAFETY INSTRUCTIONS

GENERAL SAFETY INSTRUCTIONS



CAUTION : The equipment can be dangerous if you do not follow our instructions concerning installation and servicing described in this manual and in accordance with applicable European standards and local national safety regulations.

Please carefully read all the instruction literature before operating your equipment.

Only trained operators can use the equipment.

The foreman must ensure that the operator has understood the safety instructions for this equipment as well as the instructions in the manuals for the different parts and accessories.

Read carefully all instruction manuals, label markings before operating the equipment.



















Incorrect use may result in injury. This equipment is for professional use only. It must be used only for what it has been designed for. Never modify the equipment. The parts and accessories supplied must be regularly inspected. Defective or worn parts must be replaced.

Guards (motor cover, coupling shields, connectors,...) have been designed for a safe use of the equipment.
The manufacturer will not be held responsible for bodily injury or failure and / or property damage due to destruction, the overshadowing or the partial or total removal of the guards.

Never exceed the equipment components' maximum working pressure.

Comply with regulations concerning safety, fire risks, electrical regulations in force in the country of final destination of the material. Use only products or solvent compatible with the parts in contact with the material (refer to data sheet of the material manufacturer).

PICTOGRAMS

					
NIP HAZARD	WARNING MOVING ELEVATOR	WARNING MOVING PARTS	WARNING MOVING SHOVEL	DO NOT EXCEED THIS PRESSURE	HIGH PRESSURE HAZARD
					
RELIEF OR DRAIN VALVE	WARNING HOSE UNDER PRESSURE	WEAR GLASSES OBLIGATORY	WEAR OF GLOVES IS OBLIGATORY	PRODUCT VAPOR HAZARDS	WARNING HOT PARTS OR AREAS
					
ELECTRICAL HAZARD	WARNING FIRE HAZARDS	EXPLOSION HAZARDS	GROUNDING	WARNING (USER)	WARNING SERIOUS INJURIES

PRESSURE HAZARDS



Current legislation requires that an **air relief** valve be fitted in the air supply circuit to the air motor to prevent over pressurisation. This safety feature ensures that it is not possible to supply the air motor with excessive air pressure that may cause injury.

Please ensure that a **material drain valve** is fitted in the fluid circuit to drain and depressurise the circuit. Once depressurised and drained, work /servicing may then commence on the equipment. Please remember to close these valves when restarting the system.

HIGH PRESSURE INJECTION HAZARDS



When working with high pressure equipment, special care is required. Fluid leaks can occur. There is a risk of material being injected to any exposed parts of body, this could cause severe injury :



- medical care must be sought immediately if paint is injected under the skin or in other parts of the body (eyes, fingers).
- never point the spray gun at any one. Never try to stop the spray with your hands or fingers nor with rags or similars.
- **follow the shut down procedure and always depressurize air and fluid circuits** before carrying out any servicing on the gun (cleaning, checking, maintenance of the material or cleaning of the gun nozzles).
- for the guns equipped with a safety device, always lock the trigger when not in use.

FIRE - EXPLOSION - SPARKS - STATIC ELECTRICITY HAZARDS

A poor earth connection, inadequate ventilation, sparks or static electricity can cause an explosion or fire. to avoid these risks when using or servicing SAMES KREMLIN equipment, the following safety procedures must be followed :



- ensure a good earth connection and ground the parts to be handled i.e. solvents, materials, components and equipment,
- ensure adequate ventilation,
- keep working area clean and free from waste solvents, chemicals, or solid waste i.e. rags, paper and empty chemicals drums,
- never use electrical switches / power if in an atmosphere of volatile solvent vapour,
- stop working immediately in case of electrical arcs,
- never store chemicals and solvents in the working area.
- use paint whose flash point is the highest possible to prevent from any formation of gas and inflammable vapours (refer to materials' safety instructions),
- install a cover on the drums to reduce the diffusion of gas and vapours in the spraybooth.

TOXIC PRODUCT HAZARDS



Toxic products or vapours can cause severe injury not only through contact with the body, but also if the products are ingested or inhaled. It is imperative :



- to know the material products and their risks,
- notified or hazardous materials must be stored in accordance with the regulations,
- the material must be stored in an appropriate container, never place materials in a container where there is a risk of spillage or leakage,
- a procedure must be applied for the safe disposal of waste material. It must comply with all prevailing regulations and legislations of the country where the equipment is to be used,
- protective clothing should always be worn in compliance with the material manufacturers' recommendations,
- depending on the application and chemical safety instructions, safety glasses, hearing protective earplug, gloves, foot wear, protective masks and possible breathing equipment should be worn to comply with the regulations (Refer to chapter "Safety equipment of SAMES KREMLIN selection guide).



CAUTION!

It is forbidden to use material containing high concentrations of halogenated hydrocarbon solvents with **aluminium** or **zinc fillers**. Non-compliance with the instructions may cause explosion risk causing serious or fatal injury.



EQUIPMENT REQUIREMENTS

Guards (motor cover, coupling shields, connectors,...) have been designed for a safe use of the equipment.

The manufacturer will not be held responsible for bodily injury or failure and / or property damage due to destruction, the overshadowing or the partial or total removal of the guards.

PUMP



Before carrying out any work, it is imperative to read and clearly understand the disassembly and reassembly instructions before servicing. The operator must understand the equipment and the safety instructions. These instructions are available in the equipment manuals.



The air motor is designed to be mounted with a pump. Never modify any components or couplings. When operating, please keep hands away from moving parts. Before starting up the equipment, please read the PRESSURE RELIEF instructions. Please ensure that any relief or drain valves fitted are in good working order.

HOSES

- Keep hoses out of circulation areas, moving parts or hot surfaces,
- Never expose product hoses to temperature higher than + 60°C / 140° F or lower than 0°C / 32° F,
- Never pull or use the hoses to move the equipment,
- Tighten all fittings as well as the hoses before operating the equipment,
- Check the hoses regularly; change them if they are damaged,
- Never exceed the maximum working pressure (MWP) indicated on the hose.

USED PRODUCTS

Considering the wide variety of products that are available and can be used in our equipment it is impossible to check and make recommendations for all chemical data, regarding the risks of possible chemical attack and their long term chemical reaction

SAMES KREMLIN can not be held liable for :

- compatibility of wetted parts,
- risks to staff and the surroundings,
- for worn or defective parts, for faulty equipment or units, or the quality of final product.

It is the responsibility of the user to know and prevent any possible risks such as toxic vapours, fires or explosions. He shall determine the risks of immediate reactions or pursuant to repeated exposures of the staff,

SAMES KREMLIN shall not be liable for physical injuries, direct or indirect material damages caused by the use of chemicals.

2. HANDLING



Check the weight and the dimensions of the equipment

(☞ refer to 'Technical features' section of the instruction manual

If weight and dimensions are too important, the unloading must be carried out by means of a forklift or any other appropriate means with a qualified personnel and in a clear horizontal area to prevent from risks of damage injury or an accident.

The centre of gravity is not in the centre of the machine : carry out by hand a stability-test after having lifted the whole at 10 cm / 3.937" maximum.

After the unloading, the handling of the whole (eg: elevator pump) is carried out by means of a pallet truck taking the bottom part of the frame.

Remark : Each pump motor is fitted with a ring. The ring is designed for the hoisting of one pump and can not be used for the handling of the complete assembly.

3. STORING

Storing before installation :

- Storing ambient temperature : 0 / +50 °C / 0 / +122°F
- Protect the whole against dust, water trickling, dampness and shocks.

Storing after installation :

- Operating temperature : +15 / +35 °C / +59 / +138.2° F
- Protect the whole against dust, water trickling, dampness and shocks.

4. INSTALLATION OF THE EQUIPMENT

The machine is installed on a stable horizontal floor (for eg a concrete flag).

The machine shall be made stable by the use of holding down bolts or by the use of other anchoring methods, strong enough to prevent unintended bodily movement of the equipment.



To avoid risks caused by static electricity, the equipment as well as its components must be grounded.

- **For the pumping equipments** (pumps, pneumatic rams, frame...), a section wire of 2.5 mm² is fixed on the material. Use this wire to connect the material to "the general ground". In case of severe environments (mechanical protection of the wire of earthing insufficient, vibrations, mobile material...) where function damages at the ground are probable, the user have to replace the provided wire of 2.5 mm² by a device more adapted to its environment (wire with a more important section, bonding strip, fixing by thimble with eyelet...).

The continuity of the ground must be controlled by a qualified electrician. If the continuity of the ground is not ensured, check the terminal, the wire and the earthing point. **Never** use the material without have solved this problem.

- In the severe cases of environments (mechanical protection of the wire of earthing insufficient, vibrations, mobile material...) where damages of the function put at the ground are probable, the user will have to replace the wire of 2.5 mm² provided, by a device more adapted to its environment (wire of more important section, bonding strip, fixing by thimble with eyelet...),
- **The gun** must be 'grounded' via a material hose or an air hose. In case of spraying by means of a gun with cup, the air hose must be conductive,
- **The materials to be painted** must also be grounded.

All the materials situated in the working area shall be grounded.



- **Never store** more than necessary inflammable materials inside the working area,
- The materials must be stored into **approved drums** and grounded,
- Use only grounded **metals containers** for the use of cleaning solvents,
- **Cardboard and paper are prohibited.**

5. MARKING OF THE EQUIPMENT



Each equipment has a label plate with the name of the manufacturer, the equipment part number, the interesting informations to use correctly the equipment (pressure, voltage,...) and sometimes the above pictogram.

The equipment is designed with and consists of high quality materials and components which can be re-used.

The 2012/19/UE European Directive covers all equipments with a crossed-out bin pictogram. Please inform yourself about the collection systems for electric and electronic equipments.

Please act in accordance with local rules and **do not dispose of old equipment with household wastes**. A correct disposal of old equipment will help prevent negative consequences for the environment and health.



AIRMIX® PUMPS

10C50 GT
20C50 GT

Disassembly / Reassembly

TRANSLATION FROM THE ORIGINAL MANUAL

IMPORTANT : Before assembly and start-up, please read and clearly understand all the documents relating to the equipment (professional use only).

THE PICTURES AND DRAWINGS ARE NOT CONTRACTUAL. WE RESERVE THE RIGHT TO MAKE CHANGES WITHOUT PRIOR NOTICE.

SAMES KREMLIN SAS
13, chemin de Malacher
38 240 - MEYLAN - France
 : 33 (0)4 76 41 60 60

www.sames-kremlin.com



CAUTION :

Before any action on the pump, shut off the compressed air supply and depressurize the system.

The pump is manufactured under the ATEX agreement and can not be modified. SAMES KREMLIN will not be held responsible for any failure to comply with that instruction.

Guards (air motor cover, coupling shields, housings ...) have been designed for safe use of the equipment.

The manufacturer will not be held responsible for bodily injury or failure and / or damage to property due to removal or partial removal of the guards

▪ **SUCTION VALVE (REFER TO DOC. 573.285.050)**

Unscrew the suction valve (5) by holding cylinder (2).

The ball (10) is secured on the valve (5) by means of a circlips (9).

Clean the parts.

Reinstall the suction valve and the seal (25). Replace them if necessary.

▪ **EXHAUST VALVE**

Unscrew cylinder (2) and pull it downwards.

Unscrew exhaust valve (6) by holding piston (3).

Remove ball (15).

Clean the parts and reinstall them. Be certain seal (8) is installed. Replace the parts if necessary.

▪ **LOWER MOBILE PACKING**

Unscrew cylinder (2) and pull it downwards.

Unscrew stuffing-box (7) to release GT seal (13) from exhaust valve (6).

Remount the parts in reverse order.

For that :

- Install the GT seal onto exhaust valve (6).

- Screw stuffing-box (7).

- The seal must be blocked by screwing mobile stuffing-box (7) onto exhaust valve (6).

If necessary replace seal (8) when reinstalling cylinder (2).

▪ **UPPER PACKING**

Separate the piston rod from the motor and the piston (3) from the fluid section.

Unscrew wetting-cup (4) by means of the wrench supplied with the pump.

Pull piston (3) upwards to remove upper packing (18).

Reinstall parts in reverse order. Be certain seal (21) are installed properly.

Tighten wetting-cup (4).

After reassembly, fill up the pump with solvent and increase pressure to maximum in the fluid section.

Then stop the pump and open exhaust valve to depressurize.

Retighten wetting-cup (4) by means of the wrench.

▪ **REVERSING BLOCK (REFER TO DOC. 573.087.040)**

Guards (air motor cover, coupling shields, housings ...) have been designed for safe use of the equipment.

The manufacturer will not be held responsible for bodily injury or failure and / or damage to property due to removal or partial removal of the guards

Disassemble cover (32) by removing screws CHc (33).
Dissociate female yoke (12) from reversing block lever (9).
Dismount reversing block by removing screws (10 and 8).
Reinstall the new reversing block in the reverse order of the disassembly sequence.

➔ **CAUTION** : The number of spirals must equally be distributed on each fastening parts in order to get the above dimension.

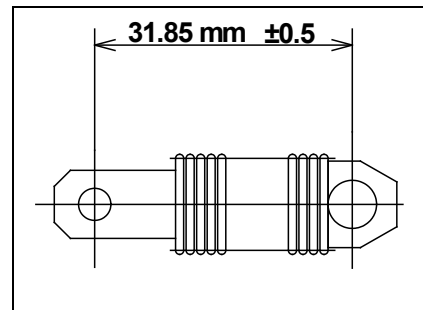

Before reassembling the different components :

- **Clean the parts with the appropriate cleaning solvent.**
- **Install new seals if it is necessary after having lubricated them with PTFE grease.**
- **Install new parts if it is necessary.**

■ ASSEMBLY INSTRUCTIONS

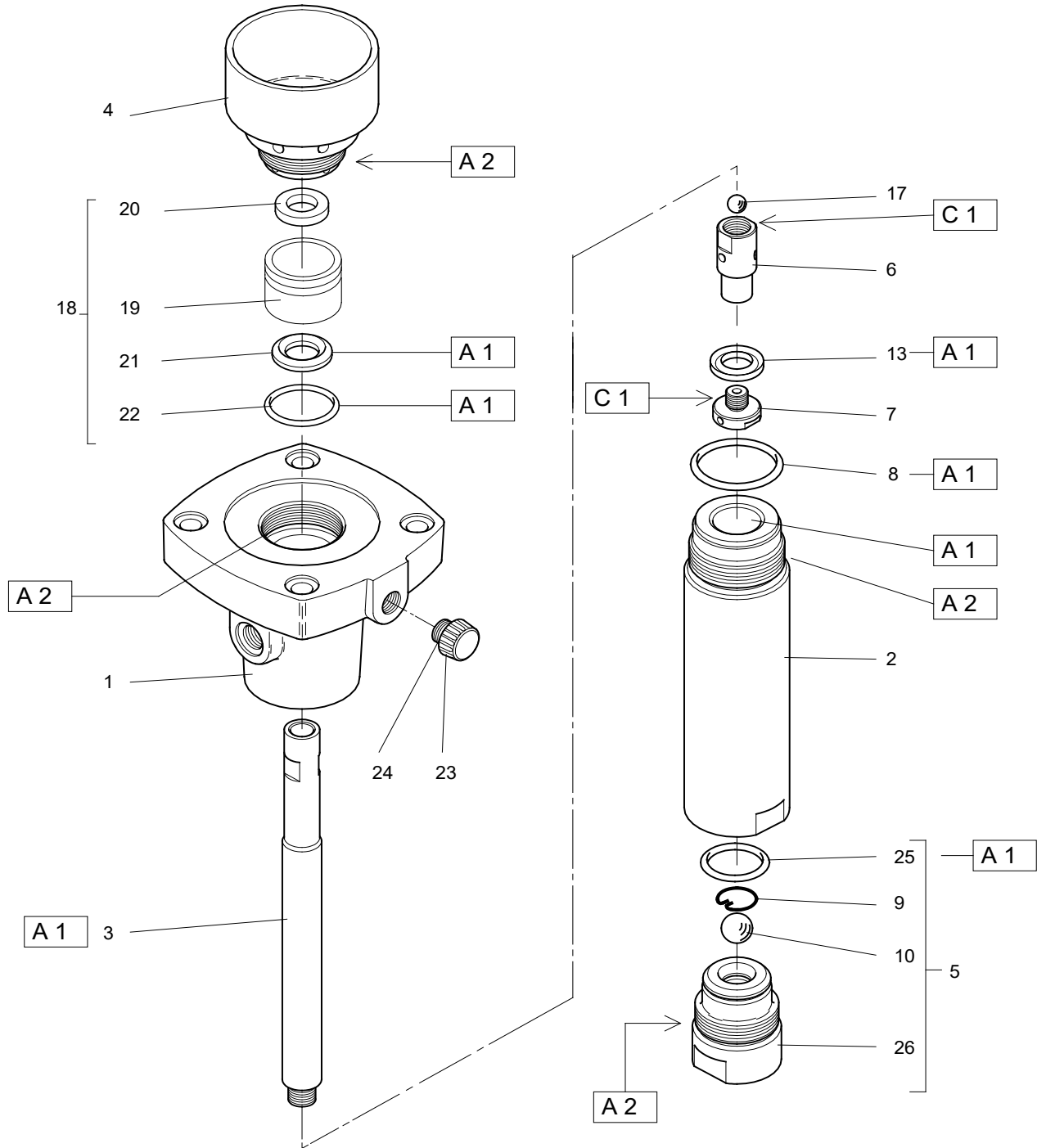

Index	Instruction	Description	Part number
A 1	PTFE grease	PTFE grease (10 ml / 0.0026 US gal)	560.440.101
A 2	Anti-seize grease	Grease box (450 g / 0.99 lb)	560.420.005
C 1	Medium strength Aneorobic Pipe sealant	Loctite 577 (250 ml / 0.066 US gal)	554.180.015

<p>Doc. 573.284.050 Date/Datum/Fecha : 12/03/19 Annule/Cancela/ Ersetzt/Anula : 19/02/14</p>	<p>Modif. / Änderung : Mise à jour / Update / Aktualisierung / Actualización KREMLIN REXSON → SAMES KREMLIN; 10-25 GT → 10C50 GT</p>	<p>Pièces de rechange Spare parts list Ersatzteilliste Piezas de repuesto</p>
--	--	---

POMPE AIRMIX®, modèle 10C50 GT	AIRMIX® PUMP, model 10C50 GT
AIRMIX® PUMPE, Modell 10C50 GT	BOMBA AIRMIX®, tipo 10C50 GT

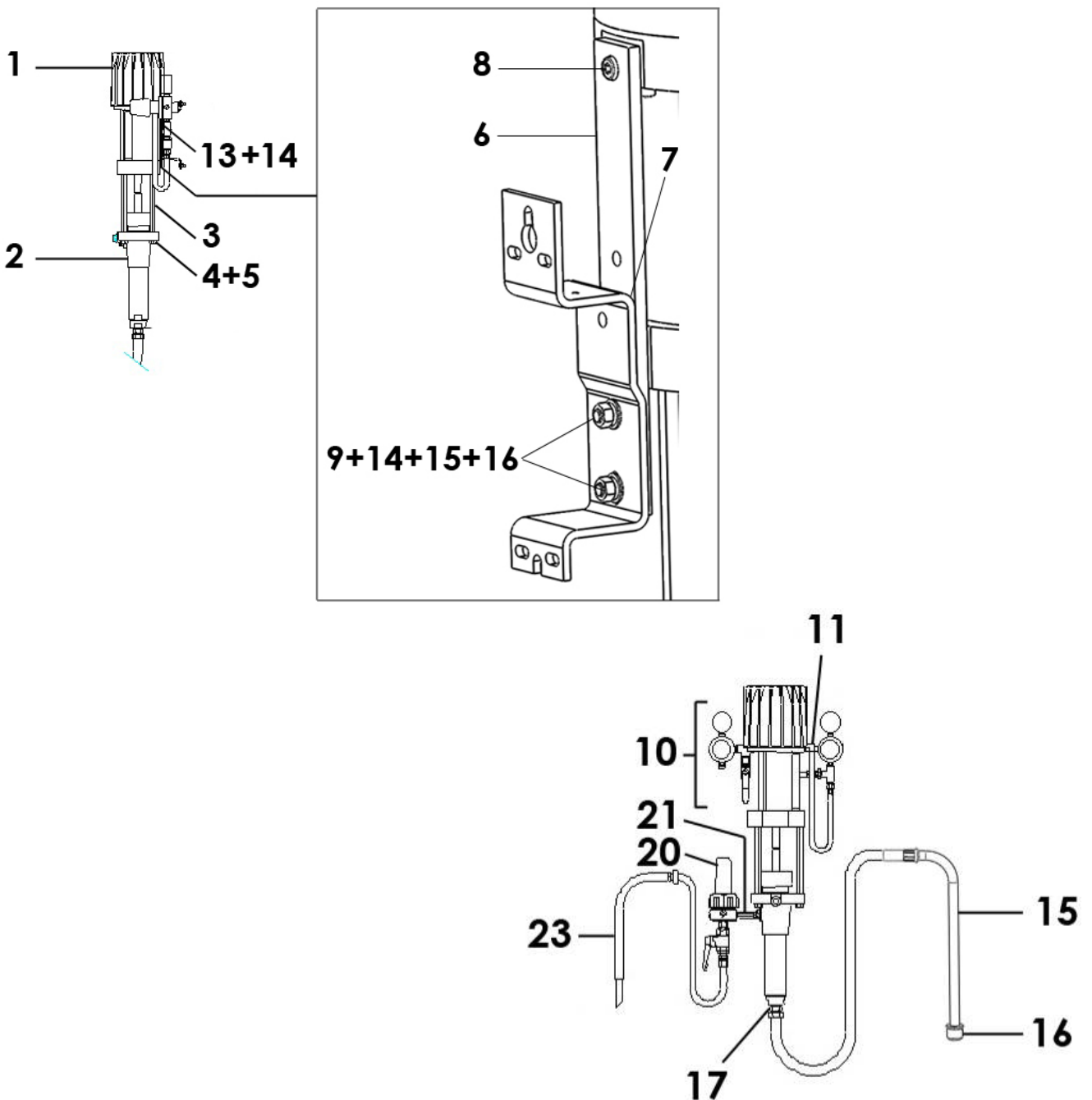

POMPE MURALE, modèle 10C50 GT sans filtre, avec canne d'aspiration	WALL MOUNTED PUMP, model 10C50 GT without filter, with suction rod	# 151.777.200
WANDANLAGE, Modell 10C50 GT ohne Filter, mit Saugschlauch	BOMBA MURAL, tipo 10C50 GT sin filtro, con caña de aspiración	

Ind	#	Désignation	Description	Bezeichnung	Denominación	Qté
-	151 777 000	Pompe 10C50 GT nue	Bare pump, model 10C50 GT	Pumpe 10C50 GT, nackt	Bomba sola, tipo 10C50 GT	1
*1	146 265 000	▪ Moteur 250-4 (voir Doc. 573.047.050)	▪ Air motor, model 250-4 (refer to Doc. 573.047.050)	▪ Luftmotor 250-4 (siehe Dok. 573.047.050)	▪ Motor, tipo 250-4 (consultar Doc. 573.047.050)	1
*2	144 950 800	▪ Hydraulique C50 GT (voir Doc. 573.285.050)	▪ Fluid section, model C50 GT (refer to Doc. 573.285.050)	▪ Hydraulikteil C50 GT (siehe Dok. 573.285.050)	▪ Hidráulica C50 GT (consultar Doc. 573.285.050)	1
3	051 770 001	▪ Tirant	▪ Tie-rod, connecting	▪ Stehbolzen	▪ Tirante	4
4	953 010 021	▪ Ecrou HM 10	▪ Nut, HM 10	▪ Mutter HM 10	▪ Tuerca HM 10	4
5	963 040 021	▪ Rondelle MN 10	▪ Washer, MN 10	▪ Scheibe MN 10	▪ Arandela MN 10	4
-	050 311 902	▪ Ressort de protection	▪ Protective spring	▪ Feder	▪ Muelle de protección	1
*-	151 775 010	Ensemble fixation	Mounting assembly	Montageplatte kpl.	Conjunto de fijación	1
6	051 770 101	▪ Plaque d'interface	▪ Plate	▪ Befestigungsplatte	▪ Placa	1
7	933 011 279	▪ Vis H 8 x 20	▪ Screw, model H 8 x 20	▪ Schraube H 8 x 20	▪ Tornillo, tipo H 8 x 20	1
8	933 151 147	▪ Vis CHc M 8 x 10	▪ Screw, model CHc M 8 x 10	▪ Schraube CHc M 8 x 10	▪ Tornillo, tipo CHc M 8 x 10	1
9	NC / NS	▪ Vis HM 8 x 25	▪ Screw, model HM 8 x 25	▪ Schraube HM 8 x 25	▪ Tornillo, tipo HM 8 x 25	2
14	88 664	▪ Rondelle W8	▪ Washer, model W8	▪ Scheibe W8	▪ Arandela, tipo W8	2
15	963 040 019	▪ Rondelle MN 8	▪ Washer, model MN 8	▪ Scheibe MN 8	▪ Arandela, tipo MN 8	2
16	953 010 019	▪ Ecrou HM 8	▪ Nut, model HM 8	▪ Mutter, model HM 8	▪ Tuerca, tipo HM 8	2
10	151 796 130	Equipement d'air (voir Doc. 573.256.050)	Air supply (refer to Doc. 573.256.050)	Luftausrüstung (siehe Dok. 573.256.050)	Equipo de aire (consultar Doc. 573.256.050)	1
11	905 150 012	Raccord coudé cannelé, M 1/4 BSP -T 8 x 12	Elbow, M 1/4 BSP - T 8 x 12	Winkelnippel AG 1/4 BSP - T 8 x 12	Racor codo, M 1/4 BSP - T 8 x 12	1
15	149 596 150	Canne d'aspiration Ø 25 (Lg. 600 mm)	Suction rod Ø 25 (Length 600 mm)	Saugschlauch Ø 25 (Länge 600 mm)	Caña de aspiración Ø 25 (Longitud 600 mm)	1
16	149 596 152	▪ Crépine Ø 25	▪ Strainer Ø 25	▪ Siebkörbe Ø 25	▪ Piña Ø 25	1
17	050 102 437	Raccord inox M 1/2 BSP - M 26 x 125	Fitting, stainless steel, double male, 1/2 BSP - 26 x 125	Doppelnippel Edelstahl AG 1/2 BSP - M 26 x 1,25	Racor, inox M 1/2 BSP - M 26 x 125	1

POMPE MURALE, modèle 10C50 GT avec filtre et canne d'aspiration	WALL MOUNTED PUMP, model 10C50 GT with filter and suction rod	#
WANDANLAGE , Modell 10C50 GT mit Filter und Saugschlauch	BOMBA MURAL, tipo 10C50 GT con filtro y caña de aspiración	151.777.100

Ind	#	Désignation	Description	Bezeichnung	Denominación	Qté
-	151 777 200	Pompe murale sans filtre	Wall mounted pump without filter	Wandpumpe ohne Filter	Bomba mural sin filtro	1
20	155 580 300	Filtre AIRMIX® inox 3/8 (voir Doc. 573.299.050)	AIRMIX® filter 3/8, stainless steel (refer to Doc. 573.299.050)	AIRMIX® Filter 3/8, Edelstahl (siehe Dok. 573.299.050)	Filtro AIRMIX® inox 3/8 (consultar Doc. 573.299.050)	1
21	055 580 301	Manchon inox MM 3/8 NPT	Sleeve, stainless steel MM 3/8 NPT	Muff Edelstahl AG 3/8 NPT	Manguito inox MM 3/8 NPT	1
23	049 596 000	Canne de purge inox	Drain rod, stainless steel	Entleerungsrohr, Edelstahl	Caña de purga inox	1

OPTIONS - ON REQUEST - OPTIONEN - OPCIONES

Ind	#	Désignation	Description	Bezeichnung	Denominación	Qté
15	149 596 160	Canne d'aspiration Ø 25 pour fût 200L (Lg. 1m)	Suction rod Ø 25 for drum 200L (Length : 1m)	Saugschlauch Ø 25 für 200L Fass (Länge : 1m)	Caña de aspiración Ø 25 para bidón de 200L (Longitud : 1m)	1
16	149 596 152	▪ Crépine Ø 25	▪ Strainer Ø 25	▪ Siebkörbe Ø 25	▪ Piña Ø 25	1

ACCESSOIRES - ACCESSORIES - ZUBEHÖR - ACCESORIOS



Ind	#	Désignation	Description	Bezeichnung	Denominación	Qté
-	149 990 020	Flacon de lubrifiant T (125 ml)	T lubricant (125 ml / 4.4 oz)	Spülmittel T (125 ml)	Botella de lubricante T (125 ml)	1
31	044 950 008	Clé (pour cuve presse-garniture)	Wrench (for wetting cup)	Schlüssel für Spülmitteltasse	Llave (para prensaestopa)	1

* Pièces de maintenance préconisées.

* Preceding the index number denotes a suggested spare part.

* Bezeichnete Teile sind empfohlene Ersatzteile.

* Piezas de mantenimiento preventivas.

N C : Non commercialisé.

N S : Denotes parts are not serviceable.

N S : Bezeichnete Teile gibt es nicht einzeln.

N S : no suministrado.

Nota : Dans le cas d'une pompe nue pour fixation murale, commander la pompe nue et le support réf. 044.910.121 (rep. 1 - Doc. 573.256.050)

Nota : For a bare pump with wall bracket, order pump only and bracket - P.N°. 044.910.121 (ind. 1 - Doc. 573.256.050)

Hinweis : Für eine nackte Pumpe mit Wandhalterung bestellen Sie die nackte Pumpe und die Halterung Bestell-Nr. 044.910.121 (Pos. 1 - Dok. 573.256.050)

Nota : En caso de una bomba sola con fijación mural, encargue Vd. la bomba sola y el soporte con la referencia 044.910.121 (ind. 1 - Doc. 573.256.050).

Doc. 573.047.050 Date/Datum/Fecha : 14/03/19 Annule/Cancel/ Ersetzt/Anula : 13/05/14	Modif. / Änderung : # 044 630 400 → NC (ind. 9a / Pos. 9a) + # 144 630 720 (ind. 9b / Pos. 9b)	Pièces de rechange Spare parts list Ersatzteilliste Piezas de repuesto
--	---	---

MOTEUR A AIR, modèle 250-4	AIR MOTOR, model 250-4	#
LUFTMOTOR, Modell 250-4	MOTOR DE AIRE, tipo 250-4	146.265.000

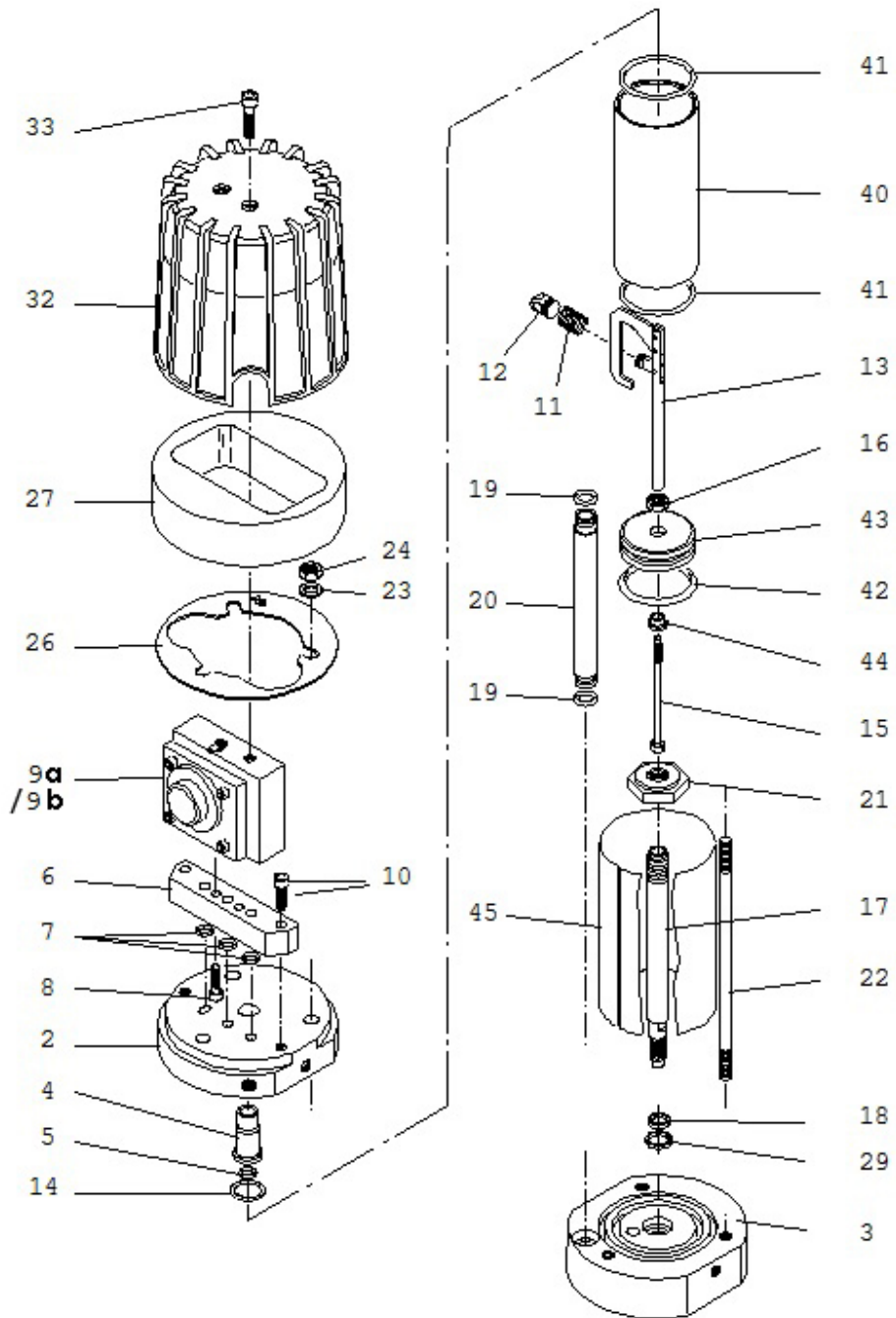

MOTEUR A AIR, modèle 250-4	AIR MOTOR, model 250-4	# 146.265.000
LUFTMOTOR, Modell 250-4	MOTOR DE AIRE, tipo 250-4	

Ind	#	Désignation	Description	Bezeichnung	Denominación	Qté
2	046 260 901	Fond supérieur	Upper flange	Oberer Flansch	Fondo superior	1
3	146 260 902	Fond inférieur	Lower flange	Unterer Flansch	Fondo inferior	1
4	044 570 106	Bague de guidage	Guide ring	Führungsbuchse	Anillo guía	1
5	144 579 923	Bague R 8 bis (x 10)	Ring, R 8 bis (x 10)	O-Ring R 8 bis (10 Stck)	Anillo R 8 bis (x 10)	1
6	046 230 005	Embase bloc inverseur	Base, reversing-block	Grundplatte, Umsteuerblock	Base bloque inductor	1
7	109 420 257	Bague O Ring (x 10)	O Ring (x 10)	O-Ring (10 Stck)	Anillo O Ring (x 10)	3
8	933 151 277	Vis CHc M 6 x 20	Screw, CHc M 6 x 20	Schraube CHc M 6 x 20	Tornillo CHc M 6 x 20	2
9a	NC / NS	Bloc inverseur (voir Doc. 573.087.040)	Reversing block (refer to Doc. 573.087.040)	Umsteuerblock (siehe Dok. 573.087.040)	Bloque inductor (consultar Doc. 573.087.040)	1
*9b	144 630 720	Bloc inverseur droit avec deux roulements (voir Doc. 573.087.040)	Right reversing-block with two bearings (refer to Doc. 573.087.040)	Rechter Umsteuerblock mit zwei Lagerbuchsen (siehe Dok. 573.087.040)	Bloque inductor derecho con dos rodamientos (consultar Doc. 573.087.040)	1
10	930 151 446	Vis CHc M 8 x 35	Screw, CHc M 8 x 35	Schraube CHc M 8 x 35	Tornillo, CHc M 8 x 35	2
11	050 311 232	Ressort	Spring	Feder	Muelle	1
12	044 570 131	Chape femelle	Linkage, female	Federhalterung	Unión hembra	1
13	044 570 900	Fourchette de commande équipée	Control fork assembly	Umsteuerstange komplett	Horquilla de mando equipada	1
14	902 202 002	Anneau truarc	Retaining ring	Sicherungsring	Anillo truarc	1
15	046 180 003	Tige de pilotage	Rod, driving	Steuerstange	Eje de mando	1
16	046 144 907	Ecrou	Nut	Mutter	Tuerca	1
17	046 180 007	Tige de piston	Rod, piston	Luftkolbenstange	Eje de pistón	1
18	046 180 010	Bague de frottement	Seal, ring	Abstreifring	Anillo de deslizamiento	1
19	129 400 902	Joint (x 10)	Seal (x 10)	Dichtringe (10 Stck)	Junta (x 10)	2
20	046 144 901	Tube d'alimentation	Tube, connecting	Luftverbindungsrohr	Tubo de alimentación	1
21	000 323 716	Contre écrou inférieur	Lower locknut	Untere Kontermutter	Contratuerca inferior	1
22	046 180 009	Tirant	Tie-rod	Verbindungsstange	Tirante	3
23	963 040 021	Rondelle MN 10	Washer, MN 10	Scheibe MN 10	Arandela MN 10	3
24	953 010 021	Ecrou HM 10	Nut, HM 10	Mutter HM 10	Tuerca HM 10	3
26	046 260 903	Rondelle de maintien	Seal	Flachdichtung	Arandela	1
27	046 230 007	Silencieux	Silencer	Schalldämpfer	Silenciador	1
29	909 420 291	Joint	Seal	Dichtring	Junta	1
32	044 570 135	Cloche	Cover	Schutzhaube	Campana	1
33	933 151 387	Vis CHc M 6 x 30	Screw, CHc M 6 x 30	Schraube CHc M 6 x 30	Tornillo, CHc M 6 x 30	2
*40	046 265 001	Cylindre	Cylinder	Luftzylinder	Cilindro	1
41	109 420 282	Joint de cylindre (x 10)	Seal, cylinder (x 10)	Zylinder O-Ring (10 Stck)	Junta de cilindro (x 10)	2
42	909 130 334	Bague R 32	Ring, R 32	Kolben O-Ring R 32	Anillo, R 32	1
*43	046 240 003	Piston	Piston	Luftkolben	Pistón	1
44	044 570 107	Butée	Stop	Anschlag	Tope	1
45	046 265 002	Virole	Muffler	Muffe	Tapa cilindro	1

Ind	#	Désignation	Description	Bezeichnung	Denominación	Qté
-	901 180 024	Cable de mise à la terre (Lg. 5 m)	Ground (Length 5 m / 196.85")	Erdungskabel (Länge 5m)	Cable de puesta a tierra (5 m de largo)	1
-	963 300 016	Rondelle	Washer	Scheibe	Arandela	1
-	934 011 196	Vis Hc 6 x 16	Screw Hc 6 x 16	Schraube Hc 6 x 16	Tornillo Hc 6 x 16	1

Ind	#	Désignation	Description	Bezeichnung	Denominación	Qté
*	146 260 991	Pochette de joints moteur (ind. 5, 7(x3), 11, 18, 19(x2), 29, 41(x2), 42 + pochette de joints inverseur)	Package of seals of the air motor (ind. 5, 7(x3), 11, 18, 19(x2), 29, 41(x2), 42 + package of seals of the reversing block)	Dichtungssatz Motor (Pos. 5, 7 (3x), 11, 18, 19 (2x), 29, 41(2x) ,42 + Dichtungssatz für Umsteuerblock)	Bolsa de juntas motor (ind. 5, 7 (x3), 11, 18, 19 (x2), 29, 41(x2), 42 + bolsa de juntas del inversor)	1
*	146 260 996	Pochette de maintenance (ind. 4 + pochette de joints moteur + ind. 2, 4, 7, 8, 13 de l'inverseur)	Servicing kit (ind. 4 + package of seals of the air motor + ind. 2, 4, 7, 8, 13 of the reversing block)	Servicekit (Pos. 4 + Dichtungssatz Luftmotor + Pos. 2, 4, 7, 8, 13 vom Umsteuerblock)	Bolsa de mantenimiento (ind. 4 + bolsa de juntas motor + ind. 2, 4, 7, 8, 13 del inversor)	1

* Pièces de maintenance préconisées tenues en stock.

* Preceding the index number denotes a suggested spare part.

* Bezeichnete Teile sind empfohlene Ersatzteile.

* Piezas de mantenimiento preventivas a tener en stock.

Nota : Les pompes dont le numéro de série est > à 17 H 1733 sont équipées du bloc inverseur # 144.630.720. Ne monter l'ind. 2 (bague de guidage du bloc inverseur) que si votre bloc comporte un R.

Nota : The pumps with serial number is > to 17 H 1733 are fitted with the reversing-block # 144.630.720. Install ind. 2 (guide ring of the reversing-block) only if your reversing-block has R.

Hinweis: Die Pumpen mit der Fertigungsnummer > bis 17 H 1733 sind mit dem Umsteuerblock # 144.630.720 bestückt. Die Pos. 2 (Führungsbuchse des Umsteuerblocks) nur am Umsteuerblock mit R Markierung montieren.

Nota : Las bombas cuyo número de serie es > a 17 H 1733 tienen el bloque inversor # 144.630.720. Montar el ind. 2 (anillo guía del bloque inversor) sólo si su bloque tiene un R.

Doc. 573.285.050 Date/Datum/Fecha : 06/03/19 Annule/Cancela/ Ersetzt/Anula : 13/03/12	Modif. / Änderung : Mise à jour / Update / Aktualisierung / Actualización	Pièces de rechange Spare parts list Ersatzteilliste Piezas de repuesto
---	--	---

HYDRAULIQUE, modèle C50 (avec garnitures GT)	FLUID SECTION, model C50 (with GT packings)	#
HYDRAULIKTEIL, Modell C50 (Packungen mit GT-Dichtung)	HIDRÁULICA, tipo C50 (guarniciones con junta GT)	144.950.800

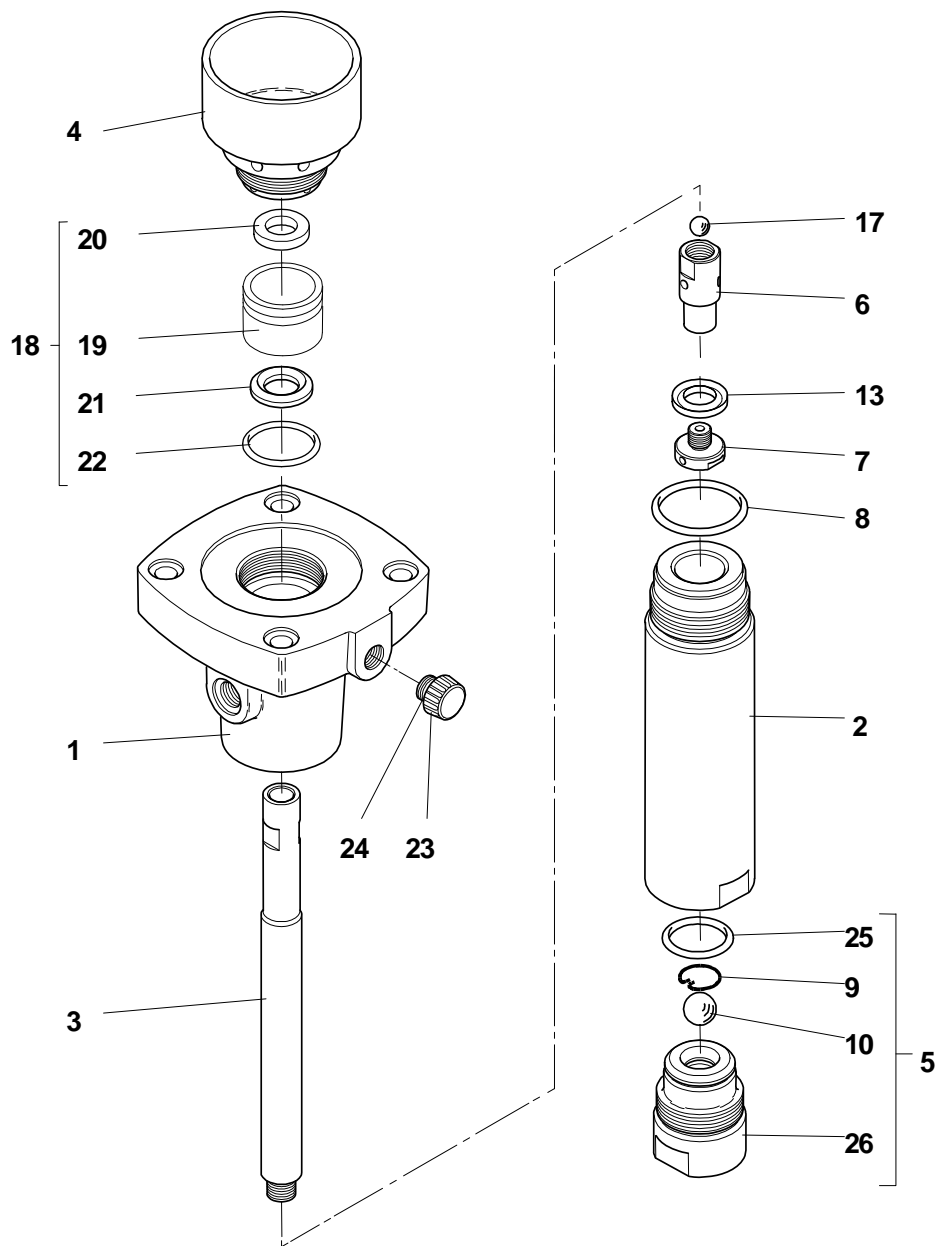

HYDRAULIQUE, modèle C50 GT	FLUID SECTION, model C50 GT
HYDRAULIKTEIL, Modell C50 GT	HIDRÁULICA, tipo C50 GT

Ind	#	Désignation	Description	Bezeichnung	Denominación	Qté
1	044 950 001	Bride supérieure	Upper flange	Oberer Flansch	Brida superior	1
*2	044 950 002	Cylindre	Cylinder	Materialzylinder	Cilindro	1
*3	044 950 003	Piston	Piston	Materialkolben	Pistón	1
4	044 950 004	Cuve presse-garniture	Wetting-cup	Spülmitteltasse	Cubeta prensa-guarnición	1
5	044 950 010	Clapet d'aspiration assemblé	Suction valve assembly	Ansaugventil, komplett	Válvula aspiración completa	1
9	044 550 029	▪ Jonc	▪ Rush	▪ Sicherungsring	▪ Anillo de retención bola	1
10	907 414 242	▪ Bille Ø 16, inox 440C	▪ Ball Ø 16 (5/8"), stainless steel 440C	▪ Kugel, Ø 16, Edelstahl 440C	▪ Bola Ø 16, inox 440C	1
25	050 040 318	▪ Joint torique	▪ O Ring	▪ O-Ring	▪ Junta O Ring	1
26	NC / NS	▪ Corps de clapet	▪ Valve body	▪ Saugventil	▪ Cuerpo de válvula	1
6	044 950 215	Clapet de refoulement	Exhaust valve	Druckventil	Válvula de expulsión	1
7	044 950 007	Presse-garniture mobile	Wetting-cup, mobile	Spülmitteltasse, mobil	Prensa-guarnición móvil	1
8	050 040 317	Joint torique	O Ring	O-Ring	Junta O Ring	1
13	909 150 214	Joint GT inférieur (garniture mobile)	Seal GT lower (mobile packing)	Unterer GT-Dichtung (mobile Packung)	Junta GT inferior (guarnición móvil)	1
17	907 414 223	Bille Ø 9,52, inox 440C	Ball Ø 9,52 (3/8"), stainless steel 440C	Kugel, Ø 9,52, Edelstahl 440C	Bola Ø 9,52, inox 440C	1
18	144 950 100	Garniture supérieure (joint GT)	Upper packing (GT seal)	Obere Packung (GT-Dichtung)	Guarnición superior (Junta GT)	1
19	NC / NS	▪ Corps de cartouche	▪ Body, upper packing	▪ Körper (obere Packung)	▪ Cuerpo	1
20	902 010 406	▪ Bague	▪ Ring	▪ Ring	▪ Anillo	1
21	909 150 212	▪ Joint GT	▪ Seal GT	▪ GT-Dichtung	▪ Junta GT	1
22	909 420 292	▪ Joint torique	▪ O Ring	▪ O-Ring	▪ Junta O Ring	1
23	144.950.012	Bouchon de vidange	Drain plug	Abläßschraube	Tapón de vaciado	1
24	109 020 401	▪ Joint plat (x 5)	▪ Flat seal (x 5)	▪ Flachdichtung (5 Stück)	▪ Junta plana (bolsa de 5)	1

OPTIONS - ON REQUEST - OPTIONEN - OPCIONES

Ind	#	Désignation	Description	Bezeichnung	Denominación	Qté
10	907 414 142	Bille Ø 16 inox 316	Ball Ø 16, 316 (stainless steel)	Kugel (Edelstahl), Ø 16, 316	Bola Ø 16, inox, 316	1
17	907 414 623	Bille Ø 9,52 inox 316	Ball Ø 9,52, 316 (stainless steel)	Kugel (Edelstahl), Ø 9,52, 316	Bola Ø 9,52, inox, 316	1

ACCESSOIRES - ACCESSORIES - ZUBEHÖR - ACCESORIOS

Ind	#	Désignation	Description	Bezeichnung	Denominación	Qté
-	149 990 020	Flacon de lubrifiant T (125 ml)	T lubricant (125 ml / 4.4 oz)	Spülmittel T (125 ml)	Botella de lubricante T (125 ml)	1

Ind	#	Désignation	Description	Bezeichnung	Denominación	Qté
*	144 950 097	Pochette de joints (ind. 8, 9, 10, 13, 17, 20, 21, 22, 24, 25)	Package of seals (ind. 8, 9, 10, 13, 17, 20, 21, 22, 24, 25)	Dichtungssatz für Hydraulikteil (beinhaltet Pos. 8, 9, 10, 13, 17, 20, 21, 22, 24, 25)	Bolsa de juntas índ. 8, 9, 10, 13, 17, 20, 21, 22, 24, 25)	1
*	144 950 098	Pochette de maintenance (ind. 5, 6 + pochette de joints)	Servicing kit (ind. 5, 6 + package of seals)	Servicekit für Hydraulikteil (beinhaltet Pos. 5, 6 und den Dichtungssatz)	Bolsa de mantenimiento (índ. 5, 6 + bolsa de juntas)	1

- * Pièces de maintenance préconisées.
- * Preceding the index number denotes a suggested spare part.
- * Bezeichnete Teile sind empfohlene Ersatzteile.
- * Piezas de mantenimiento preventivas.

- N C : Non commercialisé.
- N S : Denotes parts are not serviceable.
- N S : Bezeichnete Teile gibt es nicht einzeln, sondern nur komplett .
- N S : no suministrado.

Doc. 573.087.040 Date/Datum/Fecha : 11/05/17 Annule/Cancel/ Ersetzt/Anula : 03/06/14	Modif. / Änderung : Mise à jour / Update / Aktualisierung / Actualización + 144.630.720	Pièces de rechange Spare parts list Ersatzteilliste Piezas de repuesto
--	---	---

BLOC INVERSEUR	REVERSING-BLOCK	#
UMSTUERBLOCK	BLOQUE INVERSOR	NC / NS

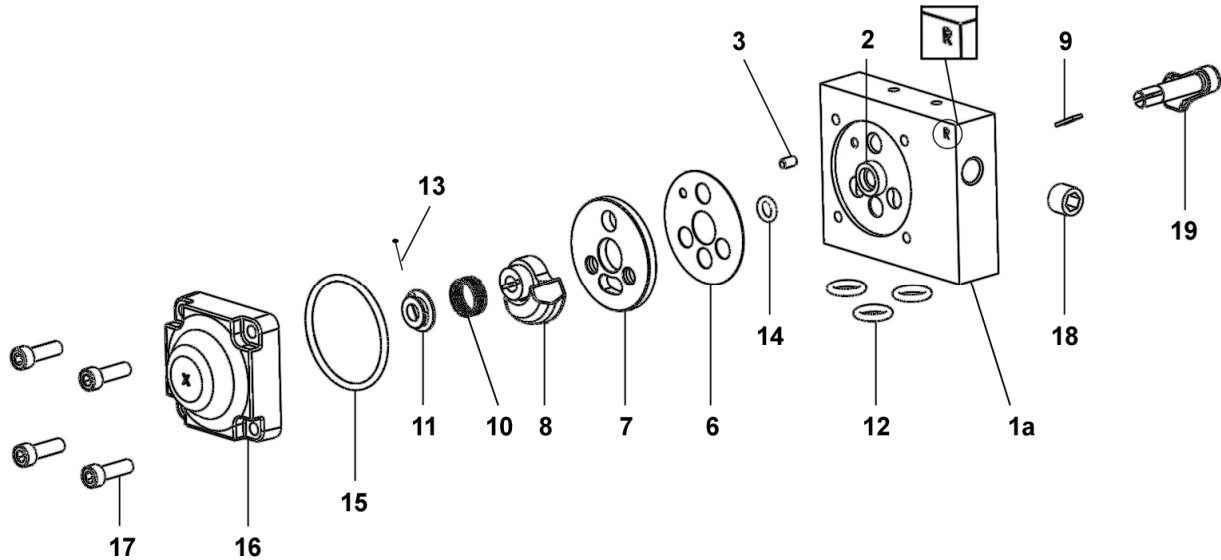

BLOC INVERSEUR DROIT AVEC DEUX ROULEMENTS	RIGHT REVERSING-BLOCK WITH TWO BEARINGS	#
RECHTER UMSTUERBLOCK MIT ZWEI LAGERBUCHSEN	BLOQUE INVERSOR DERECHO CON DOS RODAMIENTOS	144.630.720

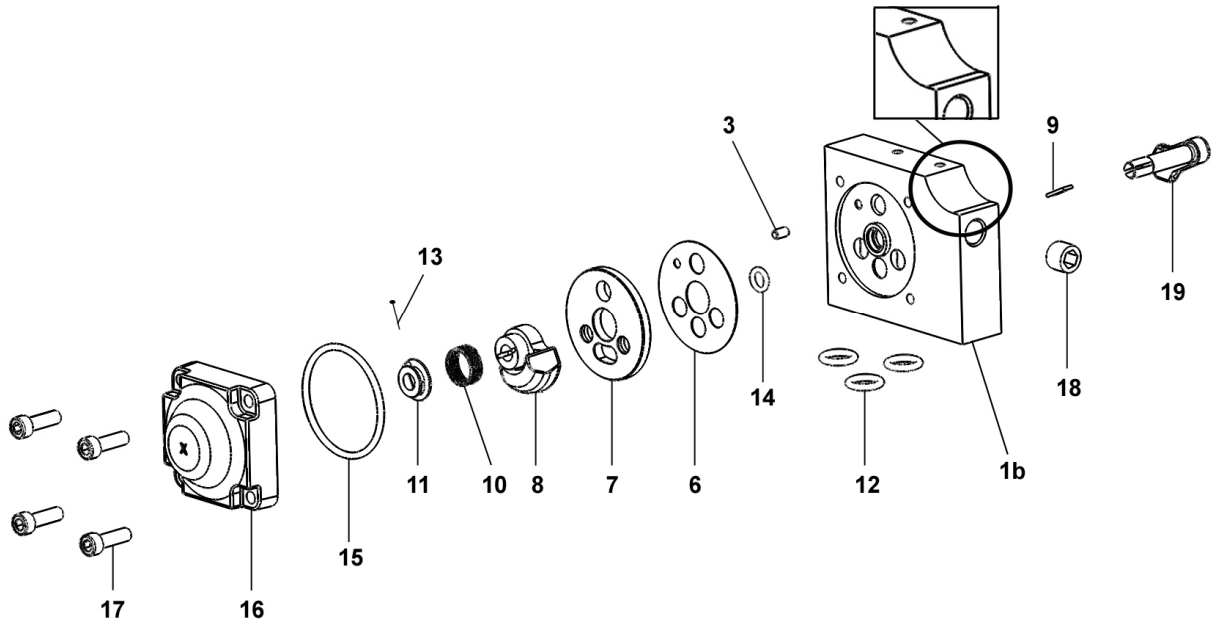

BLOC INVERSEUR	REVERSING-BLOCK	#
UMSTUEURBLOCK	BLOQUE INVERSOR	NC / NS

BLOC INVERSEUR DROIT AVEC DEUX ROULEMENTS	RIGHT REVERSING-BLOCK WITH TWO BEARINGS	#
RECHTER UMSTUEURBLOCK MIT ZWEI LAGERBUCHSEN	BLOQUE INVERSOR DERECHO CON DOS RODAMIENTOS	144.630.720

Pièces communes - Common parts - Gleiche Teile - Partes comunes

Ind	#	Désignation	Description	Bezeichnung	Denominación	Qté
*6	144 579 912	Joint de glace fixe (x 10)	Gasket seal (x 10)	Flachdichtung (10 x)	Junta de espejo fijo (x 10)	1
*7	046 170 508	Glace fixe	Base, fixed	Ventilplatte	Espejo fijo	1
*8	044 570 324	Glace mobile	Base, mobile	Ventilschieber	Espejo móvil	1
9	044 570 325	Clavette	Pin	Paßfeder (Keil)	Pasador	1
10	921 140 102	Ressort	Spring	Feder	Muelle	1
11	044 571 006	Butée de ressort	Stop, spring	Federführung	Tope de muelle	1
*12	144 579 922	Bague R 10 (x 10)	Ring, model R 10 (x 10)	O Ring R 10 (x 10)	Anillo, tipo R 10 (x 10)	3
*13	144 579 911	Goupille fendue (pochette de 10 goupilles + 1 butée ind. 11)	Pin (package of 10 pins + 1 stop ind. 11)	Splint (Satz à 10 Stück + 1 Führung Pos. 11)	Pasador (bolsa de 10 pasadores + 1 tope índ. 11)	1
*14	144 579 910	Bague R 6a (x 10)	Ring, model R 6a (x 10)	O Ring, R 6a (10 x)	Anillo, tipo R 6a (x 10)	1
*15	N C / N S	Joint de couvercle	Seal, cover	Deckeldichtung	Junta de tapa	1
16	144 630 415	Couvercle	Cover	Deckel	Tapa	1
17	933 151 277	Vis CHc M 6x20	Screw, model CHc M 6x20	Schraube, CHc M 6x20	Tornillo, tipo CHc M 6x20	4
18	906 333 102	Bouchon 1/4 BSP	Plug, model 1/4 BSP	Blindstopfen, 1/4 BSP	Tapón, tipo 1/4 BSP	1
19	046 170 510	Levier	Lever, control	Umsteuerhebel	Leva	1

Ind	#	Désignation	Description	Bezeichnung	Denominación	Qté
*	146 270 950	Pochette de joints (ind. 6, 12(x3), 14, 15)	Package of seals (ind. 6, 12(x3), 14, 15)	Dichtungssatz (bestehend aus Pos. 6, 12(x3), 14, 15)	Bolsa de juntas (ind. 6, 12(x3), 14, 15)	1
*	144 630 425	Pochette de maintenance glaces (ind. 7, 8)	Servicing kit - bases (ind. 7, 8)	Servicekit - Ventil (Pos. 7, 8)	Bolsa de mantenimiento - espejos (índ. 7, 8)	1

Pièces spécifiques - Specific parts - Spezifische Teile - Partes específicas

Pour / for / für / para # NC / NS

Ind	#	Désignation	Description	Bezeichnung	Denominación	Qté
*	144 630 410	Corps équipé	Block assembly, reversing	Umsteuerblock komplett	Cuerpo equipado	1
1a	NC / NS	▪ Corps	▪ Body	▪ Körper	▪ Cuerpo	1
2	NC / NS	▪ Bague de guidage	▪ Guide ring	▪ Führungsbuchse	▪ Anillo guía	1
3	NC / NS	▪ Goupille Ø 4 x 8	▪ Pin Ø 4 x 8	▪ Splint Ø4 x 8	▪ Pasador Ø 4 x 8	1
-	NC / NS	▪ Butée (collée sur corps ind.1a)	▪ Stop (glued on part ind. 1a)	▪ Anschlag (auf Körper geklebt ind.1a)	▪ Tope (pegado en cuerpo ind. 1a)	2
-	NC / NS	▪ Roulement à bille	▪ Ball bearing	▪ Kugellager	▪ Rodamiento de bolas	1

Pour / for / für / para # 144.630.720

Ind	#	Désignation	Description	Bezeichnung	Denominación	Qté
*	144 630 715	Corps équipé	Block assembly, reversing	Umsteuerblock komplett	Cuerpo equipado	1
1b	NC / NS	▪ Corps	▪ Body	▪ Körper	▪ Cuerpo	1
3	NC / NS	▪ Goupille Ø 4 x 8	▪ Pin Ø 4 x 8	▪ Splint Ø4 x 8	▪ Pasador Ø 4 x 8	1
-	NC / NS	▪ Butée (collée sur corps ind.1b)	▪ Stop (glued on part ind. 1b)	▪ Anschlag (auf Körper geklebt ind.1b)	▪ Tope (pegado en cuerpo ind. 1b)	2
-	NC / NS	▪ Roulement à bille	▪ Ball bearing	▪ Kugellager	▪ Rodamiento de bolas	2

* Pièces de maintenance préconisées.

* Preceding the index number denotes a suggested spare part.

* Bezeichnete Teile sind empfohlene Ersatzteile.

* Piezas de mantenimiento preventivas.

NC : Non commercialisé.

NS : Denotes parts are not serviceable.

NS : Bezeichnete Teile gibt es nicht einzeln, sondern nur komplett .

NS : no suministrado.

Nota : Ne monter l'ind. 2 (bague de guidage du bloc inverseur) que si votre bloc inverseur comporte un R.

Nota : Install ind. 2 (guide ring of the reversing-block) only if your reversing-block has R.

Hinweis: Die Pos. 2 (Führungsbuchse des Umsteuerblocks) nur am Umsteuerblock mit R Markierung montieren.

Nota : Montar el ind. 2 (anillo guía del bloque inversor) sólo si su bloque inversor tiene un R.

Doc. 573.256.050 Date/Datum/Fecha : 25/02/19 Annule/Cancel/ Ersetzt/Anula : 09/06/11	Modif. / Änderung : Mise à jour / Update / Aktualisierung / Actualización	Pièces de rechange Spare parts list Ersatzteilliste Piezas de repuesto
--	--	---

EQUIPEMENT D’AIR pour pompes AIRMIX®	AIR SUPPLY for AIRMIX® pumps	#
LUFTAUSRÜSTUNG für AIRMIX®-Pumpen	EQUIPO DE AIRE para bombas AIRMIX®	151.796.130

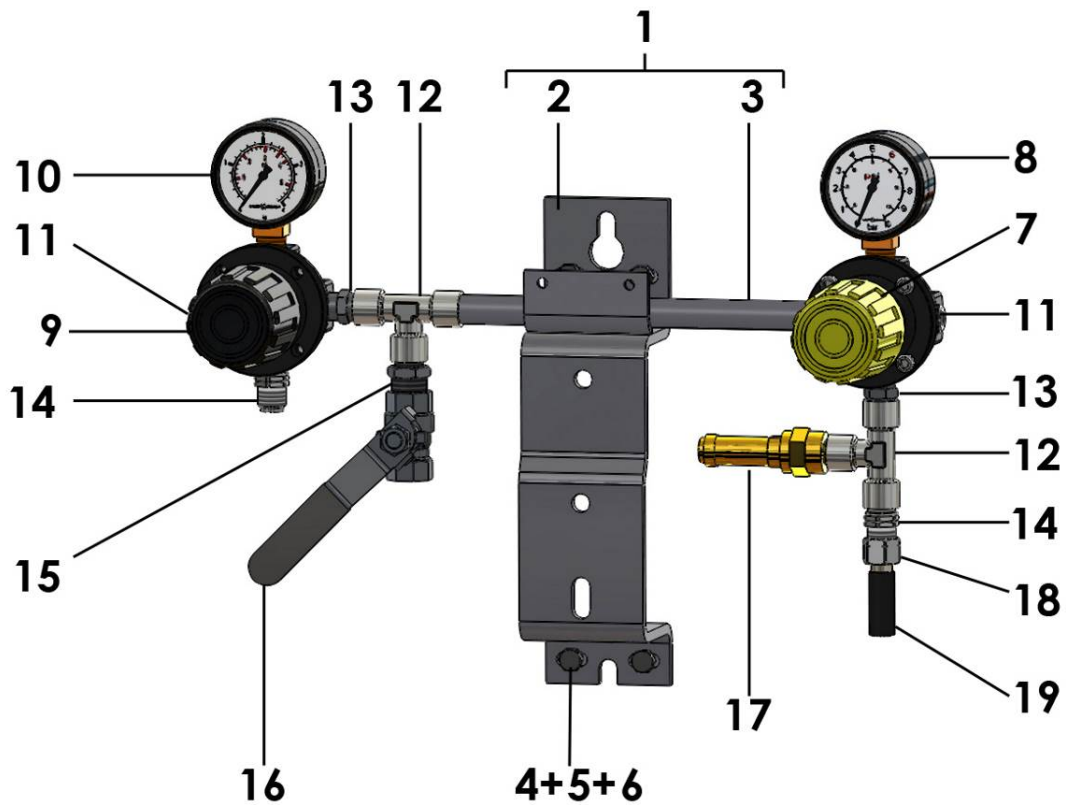

Equipement d'air	Air supply	#
Luftausrüstung	Equipo de aire	151.796.130

Ind	#	Désignation	Description	Bezeichnung	Denominación	Qté
1	044 910 121	Support pompe équipé	Pump bracket assembly	Komplette Pumpenhalterung	Soporte bomba equipado	1
2	044 910 122	▪ Support pompe	▪ Pump bracket	▪ Pumpenhalterung	▪ Soporte de bomba	1
3	051 751 011	▪ Support équipement d'air	▪ Air supply bracket	▪ Luftausrüstungshalterung	▪ Soporte equipo de aire	1
4	933 011 196	▪ Vis HM 6 x 16	▪ Screw, HM 6 x 16	▪ Schraube HM 6 x16	▪ Tornillo HM 6 x 16	6
5	953 010 016	▪ Erou HM 6	▪ Nut, HM 6	▪ Mutter HM 6	▪ Tuerca HM 6	6
6	963 040 016	▪ Rondelle M 6	▪ Washer, M 6	▪ Scheibe M 6	▪ Arandela M 6	6
7	016 370 500	Détendeur d'air 1/4 - 5,5 bar - volant phosphore (voir Doc. 573.288.040)	Air regulator, 1/4 - 5,5 bar / 79.77 psi - yellow/green knob (refer to Doc. 573.288.040)	Druckminderer, 1/4 - 5,5 bar (gelb/grün Stellglocke) (siehe Dok. 573.288.040)	Manorreductor, 1/4 - 5,5 bar (pomo amarillo/verde) (consultar Doc. 573.288.040)	1
8	910 011 402	Manomètre 0 - 10 bar	Gauge, 0 - 10 bar / 0 - 145 psi	Manometer, 0-10 bar	Manometro, 0 - 10 bar	1
9	016 380 500	Détendeur d'air 1/4 - 3,5 bar - volant noir (voir Doc. 573.288.040)	Air regulator, 1/4 - 3,5 bar / 50.76 psi - black knob (refer to Doc. 573.288.040)	Druckminderer, 1/4 - 3,5 bar (schwarze Stellglocke) (siehe Dok. 573.288.040)	Manorreductor, 1/4 - 3,5 bar (pomo negro) (consultar Doc. 573.288.040)	1
10	910 011 404	Manomètre 0 - 4 bar	Gauge, 0 - 4 bar / 0 - 58 psi	Manometer, 0 - 4 bar	Manometro, 0 - 4 bar	1
11	906 333 102	Bouchon 8 x 13	Plug, 8 x 13	Blindstopfen, 8 x 13	Tapón, 8 x 13	2
12	552 436	Té FFF 1/4 BSP	Tee, FFF 1/4 BSP	T-Stück , FFF 1/4 BSP	Te, HHH 1/4 BSP	2
13	050 102 213	Raccord MM 1/4 BSP	Fitting, double male, 1/4 BSP	Doppelnippel, M 1/4 BSP	Racor, MM 1/4 BSP	2
14	050 102 624	Raccord M 1/4 BSP - M 1/4 NPS	Fitting, double male, 1/4 BSP - 1/4 NPS	Doppelnippel, AG 1/4 BSP - 1/4 NPS	Racor, MM 1/4 BSP - 1/4 NPS	2
15	904 523 003	Raccord M 1/4 BSP - M 3/8 BSP	Fitting, double male, 1/4 BSP - 3/8 BSP	Doppelnippel, 1/4 BSP - 3/8 BSP	Racor, MM 1/4 BSP - 3/8 BSP	1
16	903 090 209	Robinet F 3/8	Valve, F 3/8	Absperrhahn, F 3/8	Grifo, H 3/8	1
17	903 080 401	Soupape de décharge - tarage 6,5 bar	Discharge valve - setting 6.5 bar / 94 psi	Sicherheitsventil - eingestellt 6,5 bar	Válvula de seguridad - tarado 6,5 bar	1
18	050 231 702	Raccord F 1/4 NPS	Adaptor F 1/4 NPS	DoppelnippelIG 1/4 NPS	Racor H 1/4 NPS	1
19	050 372 226	Tuyau 8 x 12	Hose 8 x 12	Schlauch 8 x 12	Tubería, 8 x 12	1

<p>Doc. 573.299.050 Date/Datum/Fecha : 20/07/18 Annule/Cancel/ Ersetzt/Anula : 10/06/11</p>	<p>Modif. / Änderung : Mise à jour / Update / Aktualisierung / Actualización KREMLIN REXSON → SAMES KREMLIN</p>	<p>Pièces de rechange Spare parts list Ersatzteilliste Piezas de repuesto</p>
---	--	--

FILTRE PRODUIT HP, modèle 3/8 inox	HP FLUID FILTER, model 3/8 stainless steel
HD MATERIALFILTER, Modell 3/8 Edelstahl	FILTRO PRODUCTO AP, tipo 3/8 inox

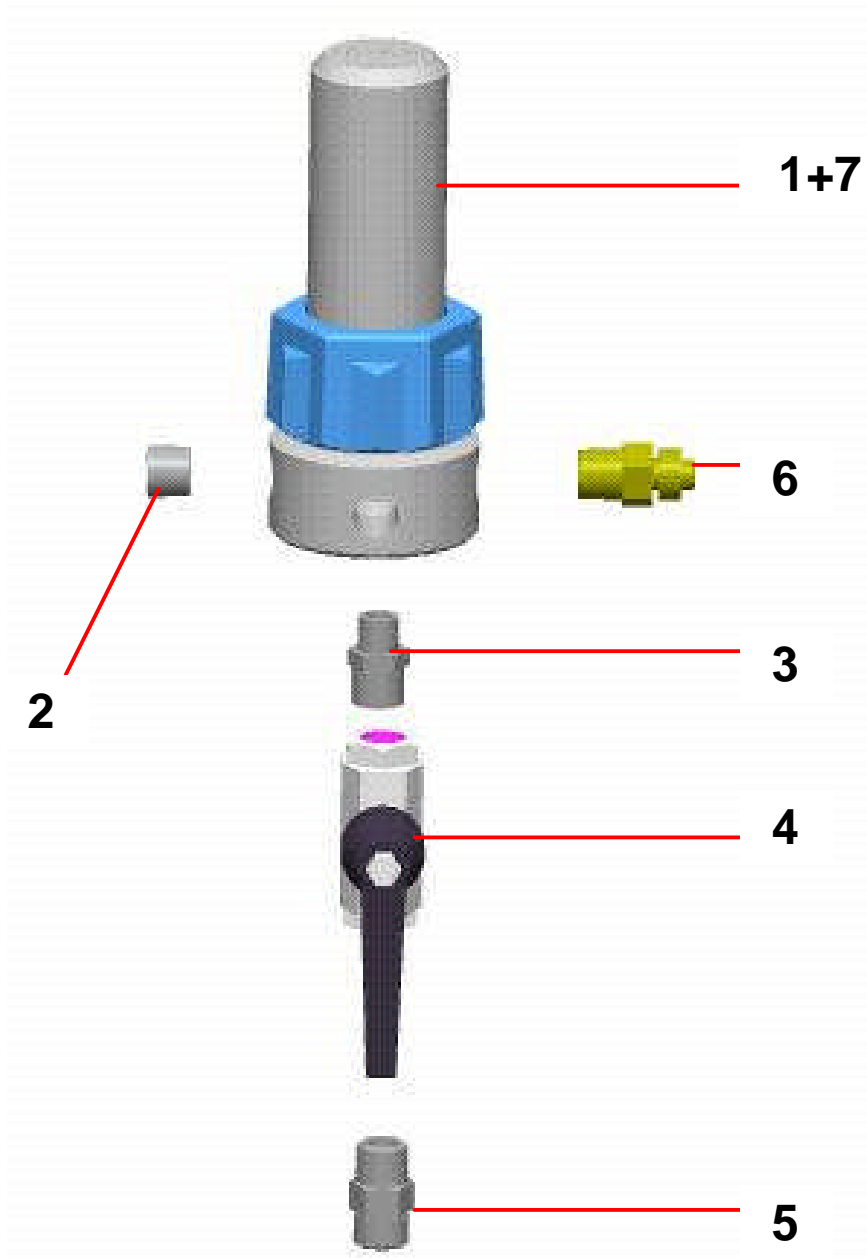

FILTRE EQUIPÉ pour pompes AIRMIX®	FILTRE EQUIPÉ pour pompes AIRLESS®
EQUIPPED FILTER for AIRMIX® pumps	EQUIPPED FILTER for AIRLESS pumps
AUSGERÜSTETER FILTER für AIRMIX®-Pumpen	AUSGERÜSTETER FILTER für AIRLESS®-Pumpen
FILTRO EQUIPADO para bombas AIRMIX®	FILTRO EQUIPADO para bombas AIRLESS®
# 155.580.300	# 155.580.400

PIECES COMMUNES - COMMON PARTS - GLEICHE TEILE - PARTES COMUNES

Ind	#	Désignation	Description	Bezeichnung	Denominación	Qté
*1	155 580 200	Filtre nu inox	Bare filter, stainless steel	Nackter Filter - Edelstahl	Filtro solo, inox	1
2	905 210 304	Bouchon inox 3/8 NPT	Plug , stainless steel 3/8 NPT	Blindstopfen - Edelstahl 3/8 NPT	Tapón de inox 3/8 NPT	1
3	906 314 204	Raccord inox M 1/4 - M 3/8	Fitting, double male, 1/4 - 3/8	Doppelnippel AG 1/4 - AG 3/8	Racor inox, M 1/4 - M 3/8	1
*4	000 750 040	Vanne HP FF 3/8 BSP	HP valve FF 3/8 BSP	Kugelhahn, IG 3/8 BSP	Válvula, AP 3/8 BSP	1
5	050 102 411	Raccord inox M 18 x 125 - M 3/8 BSP	Adaptor, stainless steel, double male 18x125 - 3/8BSP	Doppelnippel - Edelstahl AG 3/8 BSP - M 18x1,25	Racor inox, M 18 x 125 - M 3/8 BSP	1
6	905 210 503	Raccord inox M 3/8 NPT - M 1/2 JIC	Adaptor, stainless steel, double male, 3/8 NPT - # 5 JIC (1/2 JIC)	Doppelnippel Edelstahl 3/8 NPT - 1/2 JIC	Racor, inox M 3/8 NPT - M 1/2 JIC	1

PIECES SPECIFIQUES - SPECIFIC PARTS - SPEZIELLE TEILE - PARTES ESPECIFICAS

⇒ **Filtre / Filter / Filtro # 155.580.300**

Ind	#	Désignation	Description	Bezeichnung	Denominación	Qté
*7	000 161 106	Tamis n° 6 (168 µ)	Screen n° 6 (168 µ - 85 Mesh)	Filterelement Sieb Nr. 6 (168 µ)	Tamiz n° 6 (168 µ)	1

⇒ **Filtre / Filter / Filtro # 155.580.400**

Ind	#	Désignation	Description	Bezeichnung	Denominación	Qté
*7	000 161 112	Tamis n° 12 (280 µ)	Screen n° 12 (280 µ - 55 Mesh)	Filterelement Sieb Nr. 12 (280 µ)	Tamiz n° 12 (280 µ)	1

- * Pièces de maintenance préconisées.
- * Preceding the index number denotes a suggested spare part.
- * Bezeichnete Teile sind empfohlene Ersatzteile.
- * Piezas de mantenimiento preventivas.

FILTRE NU (sans tamis)	BARE FILTER (without screen)	#
NACKTER FILTER (ohne Sieb)	FILTRO SOLO (sin tamiz)	155.580.200

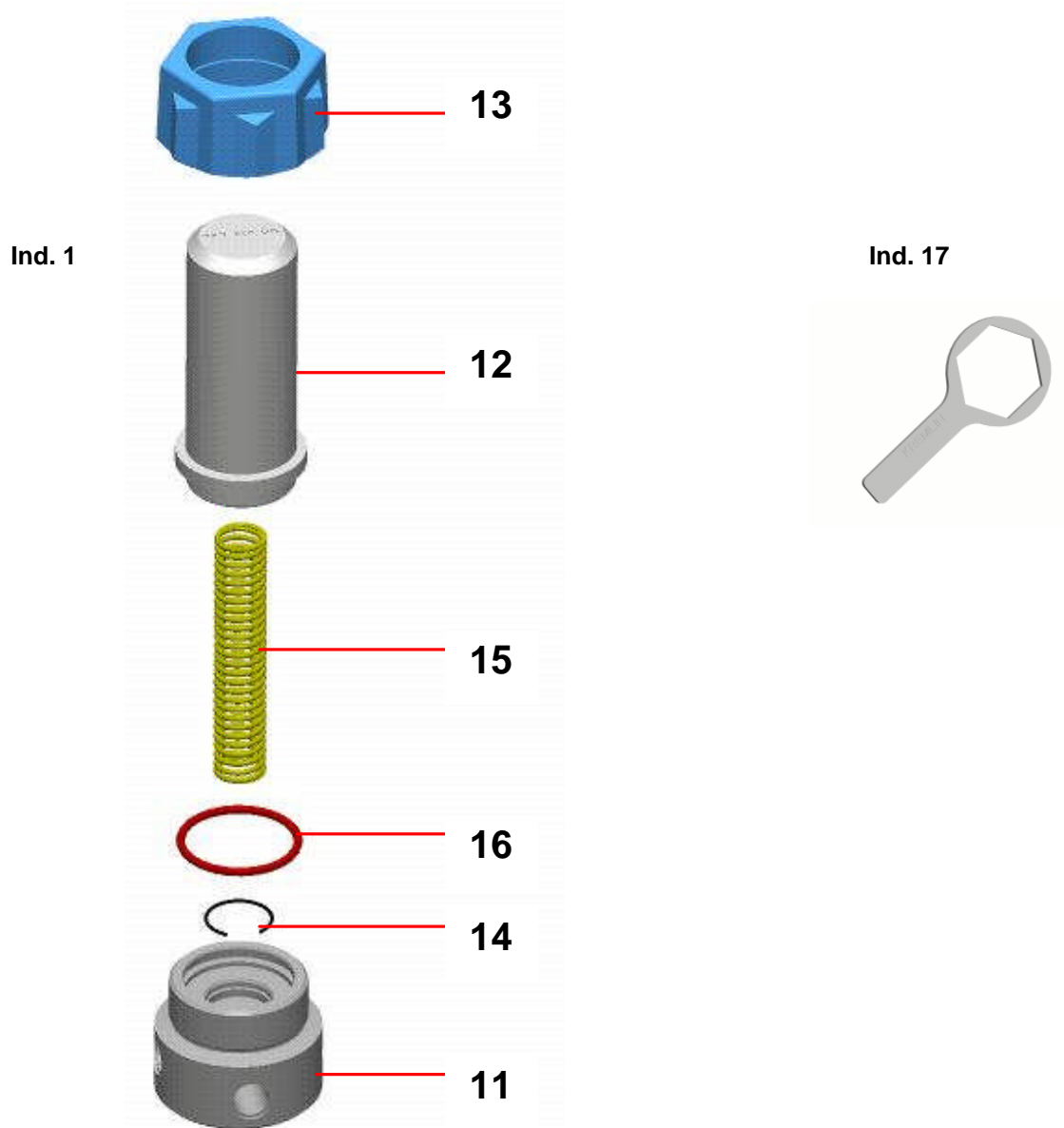

Ind	#	Désignation	Description	Bezeichnung	Denominación	Qté
11	055 580 201	Embase 3/8	Base, model 3/8	Grundblock, Modell 3/8	Base, tipo 3/8	1
12	055 580 202	Cuve	Bowl	Filterglocke	Cubeta	1
13	055 280 002	Ecrou	Nut	Überwurfmutter	Tuerca	1
14	055 190 007	Jonc	Stop ring	Sicherungsring	Clips	1
15	055 190 005	Ressort	Spring	Feder	Muelle	1
*16	150 040 327	Joint (les 5)	Seal (pack of 5)	Dichtung (5 St.)	Junta (bolsa de 5)	1
17	049 030 018	Clé de démontage	Wrench	Schlüssel	Llave de desmontaje	1

A LA DEMANDE - ON REQUEST - AUF WUNSCH - A PETICIÓN

Ind. 7



Ind	#	Désignation	Description	Bezeichnung	Denominación	Qté
-	000 161 101	Tamis n° 1 (37 µ)	Screen n° 1 (37 µ)	Sieb Nr. 1 (37 µ)	Tamiz n° 1 (37µ)	1
-	000 161 102	Tamis n° 2 (77 µ)	Screen n° 2 (77 µ)	Sieb Nr. 2 (77 µ)	Tamiz n° 2 (77 µ)	1
-	000 161 104	Tamis n° 4 (99 µ)	Screen n° 4 (99 µ)	Sieb Nr. 4 (99 µ)	Tamiz n° 4 (99 µ)	1
7	000 161 106	Tamis n° 6 (168 µ)	Screen n° 6 (168 µ)	Sieb Nr. 6 (168 µ)	Tamiz n° 6 (168 µ)	1
-	000 161 108	Tamis n° 8 (210 µ)	Screen n° 8 (210 µ)	Sieb Nr. 8 (210 µ)	Tamiz n° 8 (210 µ)	1
7	000 161 112	Tamis n° 12 (280 µ)	Screen n° 12 (280 µ)	Sieb Nr. 12 (280 µ)	Tamiz n° 12 (280 µ)	1
-	000 161 115	Tamis n° 15 (360 µ)	Screen n° 15 (360 µ)	Sieb Nr. 15 (360 µ)	Tamiz n° 15 (360 µ)	1
-	000 161 020	Tamis n° 20 (510 µ)	Screen n° 20 (510 µ)	Sieb Nr. 20 (510 µ)	Tamiz n° 20 (510 µ)	1
-	000 161 030	Tamis n° 30 (750 µ)	Screen n° 30 (750 µ)	Sieb Nr. 30 (750 µ)	Tamiz n° 30 (750 µ)	1

OPTIONS - ON REQUEST - OPTIONEN - OPCIONES

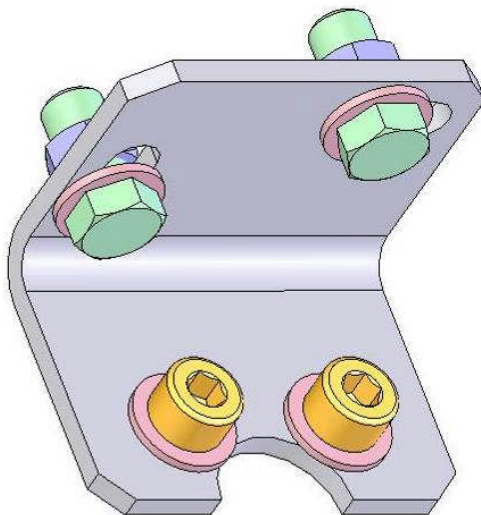

Ind	#	Désignation	Description	Bezeichnung	Denominación	Qté
-	155 190 105	Support filtre avec vis, rondelles et écrous	Mounting bracket with screws, washers and nuts	Filterhalterung mit Schrauben, Scheiben und Muttern	Soporte filtro con tornillos, arandelas y tuercas	1



**AIRMIX ® PUMP and
LOW-PRESSURE PUMP
air motor with reversing block
*PREVENTIVE MAINTENANCE***

TRANSLATION FROM THE ORIGINAL MANUAL

IMPORTANT : Before assembly and start-up, please read and clearly understand all the documents relating to this equipment (professional use only).

THE PICTURES AND DRAWINGS ARE NON CONTRACTUAL. WE RESERVE THE RIGHT TO MAKE CHANGES WITHOUT PRIOR NOTICE.

SAMES KREMLIN SAS
13, chemin de Malacher
38 240 - MEYLAN - France
☎ : 33 (0)4 76 41 60 60

www.sames-kremlin.com

▪ PUMP

Make sure that the pump is clean and in good condition to increase equipment working life.

If the pump is an intensive™ one :

- Regularly clean the wetting-cup with "T" lubricant (this "T" lubricant will normally be coloured by the paint).
- Regularly clean the wetting-cup with solvent after having drained the lubricant (unscrew the plug on the upper flange).

**Guards (air motor cover, coupling shields, housings,...) have been designed for safe use of the equipment.
The manufacturer will not be held responsible for bodily injury or failure and / or damage to property due to removal or partial or removal of the guards.**

Make sure that the suction strainer is clean and in good condition. Regularly clean it and change it if necessary.

Flush the pump as often as necessary, specially when spraying pigment-filled material.

**Whatever the case, when stopping the pump, always leave it filled with material.
For a short duration shutdown, if the flushing has not been carried out, leave the pump filled with material.
For a short duration shutdown, after flushing the pump, leave it filled with solvent.**

▪ SPRAY GUN

Comply with the usual instructions of spray gun servicing (refer to spray gun instruction manual).

▪ FILTER

If the pump is mounted with a filter at the fluid outlet, comply with the usual instructions of filter servicing (refer to filter instruction manual)



**AIRMIX ® PUMP and
LOW-PRESSURE PUMP
air motor with reversing block
*TROUBLESHOOTING***

TRANSLATION FROM THE ORIGINAL MANUAL

IMPORTANT : Before assembly and start-up, please read and clearly understand all the documents relating to this equipment (professional use only).

THE PICTURES AND DRAWINGS ARE NON CONTRACTUAL. WE RESERVE THE RIGHT TO MAKE CHANGES WITHOUT PRIOR NOTICE.

SAMES KREMLIN SAS
13, chemin de Malacher
38 240 - MEYLAN - France
☎ : 33 (0)4 76 41 60 60

www.sames-kremlin.com

CAUSE	SOLUTION
The pump does not start.	Check the pump air supply.
Priming trouble : → Air is always coming out from the spray gun. → Air (or material) does not come out from the spray gun.	Be sure that the spray gun is fully opened and air evacuated through this one. Air intake at the fitting or at the suction rod. Check the pump valves. If a valve is stucked by dry paint, it can be unsticked without disassembling it. Blow air pressure directly by suction fitting.
The pump does not stop at once when shutting off the spray gun : → The pump stops only on down stroke. → The pump stops only on up stroke.	Check exhaust valve or valve seal. Check suction valve or upper cartridge.
The pump does not reverse.	Check spring of the air motor reversing block. Lubricate reversing-block with HP 150 oil. Check is there is pilot air (depending on air motor model).
On intensive™ pump, the lubricant into the cup is fastly coloured.	Check the upper packing (tighten the cup or change seals if it is necessary).
On FLOWMAX® pump, leakage of fluid at the bottom of the air motor.	Check bellow.
Spraying trouble.	Refer to spray gun instruction manual.
Decrease of material flow.	Refer to filter instruction manual.



**AIRMIX ® PUMP
and LOW-PRESSURE PUMP
air motor with reversing block
*OPERATING PRINCIPLE AND START-UP***

TRANSLATION FROM THE ORIGINAL MANUAL

IMPORTANT : Before assembly and start-up, please read and clearly understand all the documents relating to this equipment (professional use only).

THE PICTURES AND DRAWINGS ARE NON CONTRACTUAL. WE RESERVE THE RIGHT TO MAKE CHANGES WITHOUT PRIOR NOTICE.

SAMES KREMLIN SAS
13, chemin de Malacher
38 240 - MEYLAN - France
☎ : 33 (0)4 76 41 60 60

www.sames-kremlin.com

1. OPERATING PRINCIPLE

The pump (A) consists of :

- an alternating air motor (B),
- an hydraulic section (C) mechanically coupled to the air motor (B).

The air motor is supplied with compressed air by means of the regulator (D) (yellow/green knob). The pressure is read on the gauge (E).

During its alternating movement, the air motor drives the piston of the hydraulic section (C). The fluid is drawn in (L) and forced under pressure in (N). Due to its design, the pressure is always the one read on the gauge x pump ratio.

The spray air pressure of the gun is adjusted by means of the regulator (black knob) (F).

⇒ To adjust the fluid flow rate, turn the yellow/green knob (D) - (Gauge E).

⇒ To adjust the spray air, turn the black knob (F) - (Gauge G).

The pumps are intensive™ ones or Flowmax ® ones (with bellows).

2. START UP

2-1 FILLING

INTENSIVE™ PUMP

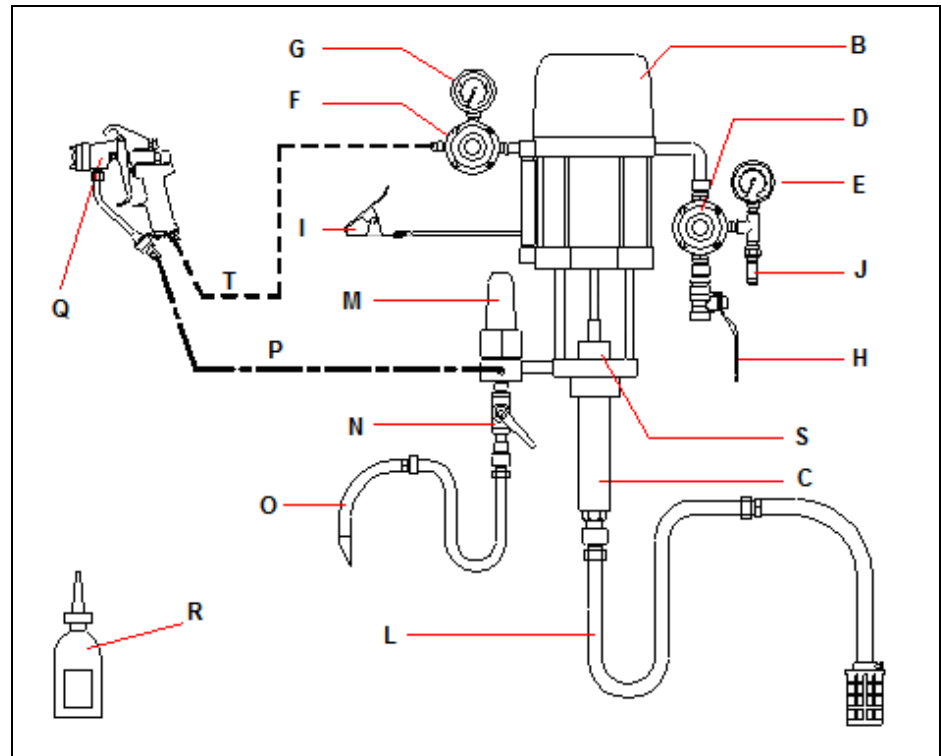

FLOWMAX ® PUMP

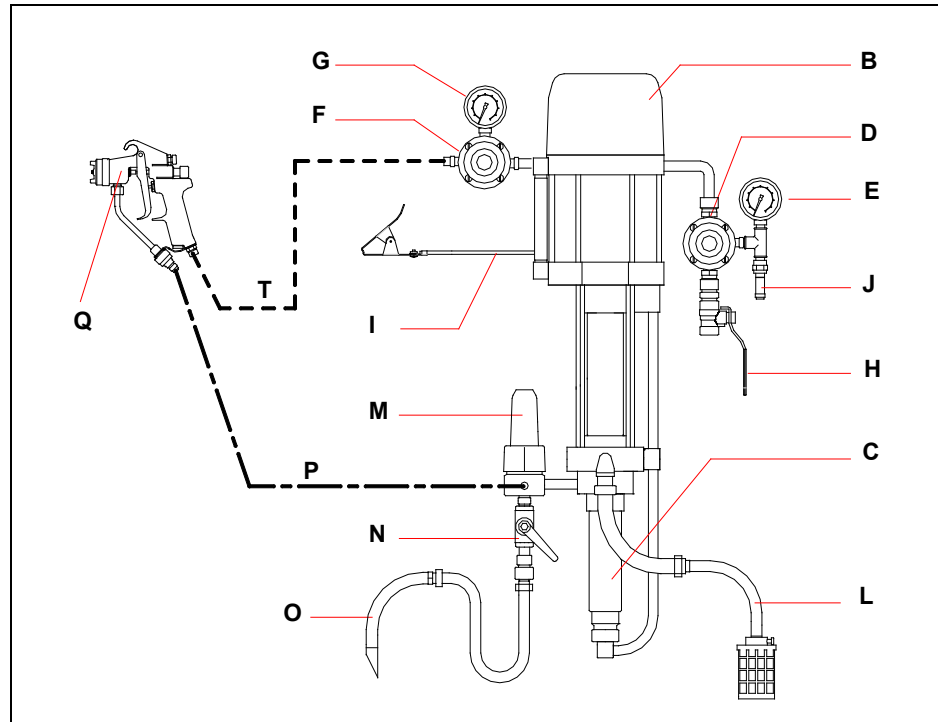

Captions :

A	Intensive™ or FLOWMAX ® pump (B + C)	L	Suction rod (depending on version)
B	Air motor	M	Accumulator filter (depending on version)
C	Fluid section	N	Drain valve (depending on version)
D	Air regulator "MOTOR AIR"	O	Drain rod (depending on version)
E	Gauge	P	HP Fluid hose
F	Air regulator "GUN AIR" (depending on version)	Q	Spray gun
G	Gauge (depending on version)	R	"T" lubricant (1/4 l / 0.07 US gal) (only for intensive™ pump)
H	Air inlet valve	S	Wetting-cup (only for intensive™ pump)
I	Ground	T	Air hose (static conductor)
J	Discharge valve		

(For specific installation, please contact your SAMES KREMLIN representative).

Nota : If the pump is equipped with an accumulator filter (M), the filter is supplied with a stainless steel screen n° 6 (filtration size : 168 microns or 85 mesh). The screen is recommended for the use of an AIRMIX gun fitted with a nozzle model n° 6. If the fluid spraying is carried out by means of an other nozzle, choose an other screen (refer to the filter instruction manual). Adjust the screen to the application.

Start up procedure :

- 1 - Ground the pump.
- 2 - **If the pump is a intensive™ one, fill up the wetting-cup (S) with "T" lubricant (R) or with an appropriate solvent.**
- 3 - Unscrew the air regulators (D and F).
- 4 - Interconnect the air equipment with the air pressure network (clean air - Pressure < 6 bar / 87 psi). Install a water drop, model 3/4" (or model 3/8" if the pump is equipped with an air motor, model 500/4), if it is necessary.
- 5 - Connect all the hoses, air hose and fluid hose (P), as well as the spray gun (Q).
Nota : Comply with the diameters of hoses recommended in the specifications of the pump.
- 6 - Remove the nozzle from the spray gun.

▪ **FLUSHING WITH SOLVENT**

- 7 - Immerse suction rod (L) and the drain rod (O) into the material container.
- 8 - Open the air shut off valve (N).
- 9 - Open the valve (H) of the pump air equipment to supply the air motor.

Nota : If the pump air motor is a 5000 version, it needs pilot air to operate. The pump air equipment supplies pilot air to the air motor. The air supply pressure is adjusted previously in the factory to 4 bar / 58 psi maximum.

- 10 - Increase **progressively** the air regulator (D) so that the pump runs slowly (Pressure between 0.5 to 1 bar / 7.25 to 14.503 psi).
- 11 - Observe the drain (O); air bubbles come out from it. When bubbles no longer come out from it, shut off the drain valve (N).

▪ **PRIMING WITH MATERIAL**

- 12 - Remove the suction rod (L) and the drain rod (O) from the material container and immerse them in a solvent filled container.
- 13 - Open the drain valve (N), wait until the material flows out regularly, then shut off the drain valve (N).
- 14 - Point the spray gun towards the material container and trigger the spray gun until the material flows out regularly.

▪ **WORK**

- 15 - Reinstall the ring and the aircap on the spray gun.
- 16 - Adjust air regulator (D) to obtain the appropriate material pressure and flow rate.
- 17 - **Gradually** open the air regulator (F) to adjust the spraying air to obtain the required spray pattern.

Nota : Some of these pumps are not equipped in the intensive™ version with the air regulator (F).

A spraying air kit can be mounted on the pump air equipment in order to supply compressed air to the spray gun if it is necessary.

2-2 PUMP SUPPLIED IN FILLING (CIRCULATING)

Interconnect the pump fluid inlet with the circulating supply hose and start up the pump as it is specified previously.

If the pump is a FLOWMAX ® one :

WARNING:

- **Fluid section filling pressure** : 2 bar / 29 psi maximum
- **WARNING : Do not create overpressure**
- **NEVER use** the pump when **an isolating gate on the supply circuit** (upstream from the FLOWMAX ® fluid section) is shut : **it would damage the bellows.**
- **Do not install** a material regulator on the supply circuit or any arrangement that could perform as a non-return valve.

3. SHUTDOWN AT THE END OF THE WORK

▪ SHORT DURATION SHUTDOWN

- 1 - Decrease the material pressure of air regulator (D) until reading **0 bar / 0 psi** on the gauge (E).
- 2 - Trigger the spray gun to depressurize the system.
- 3 - Unscrew the spray gun air regulator (F) or disconnect the spray gun air inlet.
- 4 - Remove the aircap from the spray gun, (aircap and nozzle for Airmix ® spray gun) and soak it into solvent.

▪ LONG DURATION SHUTDOWN

- 1 - Decrease the air regulator (D) until reading **1 bar / 14.503 psi** on gauge (E).
- 2 - Unscrew the spray gun air regulator (F) or disconnect the spray gun air inlet.
- 3 - Remove the spray gun aircap, (aircap and nozzle for AIRMIX ® spray gun) and soak it into solvent.
- 4 - Open the drain valve. The pump must operate slowly. If the speed is too high, decrease the air regulator (D) pressure.
- 5 - Remove the suction rod and the drain rod from the material container and immerse them in a solvent-filled container. Take all the appropriate precautions in the presence of flammable solvents.
- 6 - When the solvent flows out regularly, close the drain valve.
- 7 - Point the spray gun towards the material container and press the gun trigger. When the solvent flows out, point the spray gun towards the recovery container.
- 8 - When the solvent flows out, release the spray gun trigger.

Nota : If the pump is a intensive™ one, release the spray gun trigger when the pump is in a low position. To prevent from damaging the seals when starting the pump, the piston must be immersed into solvent.

- 9 - Fully unscrew the air regulator (D) and shut off the main compressed air valve (valve H).
- 10 - Press the spray gun trigger to decompress the hoses. Therefore, the pump and the hose remain filled with solvent at the atmospheric pressure

4. SAFETY DEVICE

Guards (air motor cover, coupling shields, housings ...) have been designed for safe use of the equipment.

The manufacturer will not be held responsible for bodily injury or failure and / or damage to property due to removal or partial removal of the guards

A relief-valve (setting : 6.5 bar / 94 psi) is fitted on the pump air motor - thus protecting this one from an overpressure which could damage it.



AIRMIX® PUMPS

10C50 GT

20C50 GT

TECHNICAL FEATURES

TRANSLATION FROM THE ORIGINAL MANUAL

IMPORTANT : Before assembly and start-up, please read and clearly understand all the documents relating to this equipment (professional use only).

THE PICTURES AND DRAWINGS ARE NON CONTRACTUAL. WE RESERVE THE RIGHT TO MAKE CHANGES WITHOUT PRIOR NOTICE.

SAMES KREMLIN SAS

13, chemin de Malacher
38 240 - MEYLAN - France

 : 33 (0)4 76 41 60 60

www.sames-kremlin.com

1. DESCRIPTION

- Stainless steel pump
- Low maintenance and ease of use

Recommended for :

- Supplying one or several spray guns
- Water-based or solvent-based paints whose viscosity is lower than 1000 mPa/s

2. TECHNICAL FEATURES

▪ **FEATURES PUMP, MODEL 10C50 GT**

Motor model250-4
 Body pump modelC50 GT
 Theoretical pressure ratio 10/1

Wetted parts :

Hard chrome stainless steel, stainless steel, carbide, polyacetal.

Tightness packings :

Upper fixed : packing with GT seal
 Lower, mobile : GT seal

Air motor stroke	100 mm	4 inch.
Air motor section	25 cm ²	3.9 sq.in
Fluid section	2.5 cm ²	0.4 sq.in
Delivery per cycle	50 cc	1.76 oz
Number of cycle	20 per liter	76 per gallon
Fluid delivery (30 cycles).	1,5 l	0.4 US gal
Max. air operating pressure	6 bar	87 psi
Maximum discharge pressure	60 bar	870 psi
Weighted sound pressure (LAeq)	78,4 dBA*	78,4 dBA*
Max. operating temperature	60°C	140 ° F
Weight	17 kg	37.5 lbs

* **Test conditions - Noise level :**

- Test duration : 30 s,
- Motor air pressure : 6 bar,
- Material used : water,
- Flow rate : Pump adjusted at 20 cycles/minute

▪ **FEATURES PUMP, MODEL 20C50 GT**

Motor model 500-4
 Body pump modelC50 GT
 Theoretical pressure ratio 20/1

Wetted parts :

Hard chrome stainless steel, Stainless steel, Carbide, Polyacetale.

Tightness packings :

Upper fixed : cartridge with GT seal
 Lower, mobile : GT seal

Air motor stroke	100 mm	4 inch
Air motor section	50 cm ²	7.8 sq.in
Fluid section	2,5 cm ²	0.4 sq.in
Delivery per cycle	50 cc	1.76 oz
Number of cycle	20 per liter	76 per gallon
Fluid delivery (30 cycles).	1,5 l	0.4 US gal
Max. air operating pressure	6 bar	87 psi
Maximum discharge pressure	120 bar	1740 psi
Weighted sound pressure (LAeq)	78,4 dBA*	78,4 dBA*
Max. operating temperature	60° C	140° F
Weight	17 kg	37.5 lbs

* **Test conditions - Noise level :**

- Test duration : 30 s,
- Motor air pressure : 6 bar,
- Material used : water,
- Flow rate : Pump adjusted at 20 cycles/minute

▪ **FITTINGS**

		Bare pump	Pump assembly
Air	Inlet	Female 1/4 BSP	Female 3/8 BSP (air supply)
Fluid	Inlet	Female 1/2 BSP	Male 26 x 125 + suction rod (fitting F 26 x 125)
	Outlet	Female 3/8 NPS	Male 1/2 JIC (filter outlet)

▪ **HOSES WITH FITTINGS**

Pump air supply (minimum Ø for a 5 m / 16.5 ft length) :

Ø 10 mm 3/8 dia.

Air hose (between "GUN AIR" regulator and gun) :

7 mm ID / 1/4 dia.

AIRMIX® fluid hose (between pump fluid outlet and gun) :

4.8 mm ID / 3/16 dia.

▪ **DIMENSIONS**

Ind.	mm	"	Ind.	mm	"	Ind.	mm	"
A	350	13.8	B	160	6.3	C	820	32.3
D	210	8.3	E	182	7.16	F	35	1.38
G	36,5	1.43	H	60	2.36	I	211,5	8.3
J	Ø 7x 15	Ø 0.27 x 0.6	K	Ø 17	Ø 0.67	L	Ø 9	Ø 0.35
M	Ø 9	Ø 0.35						

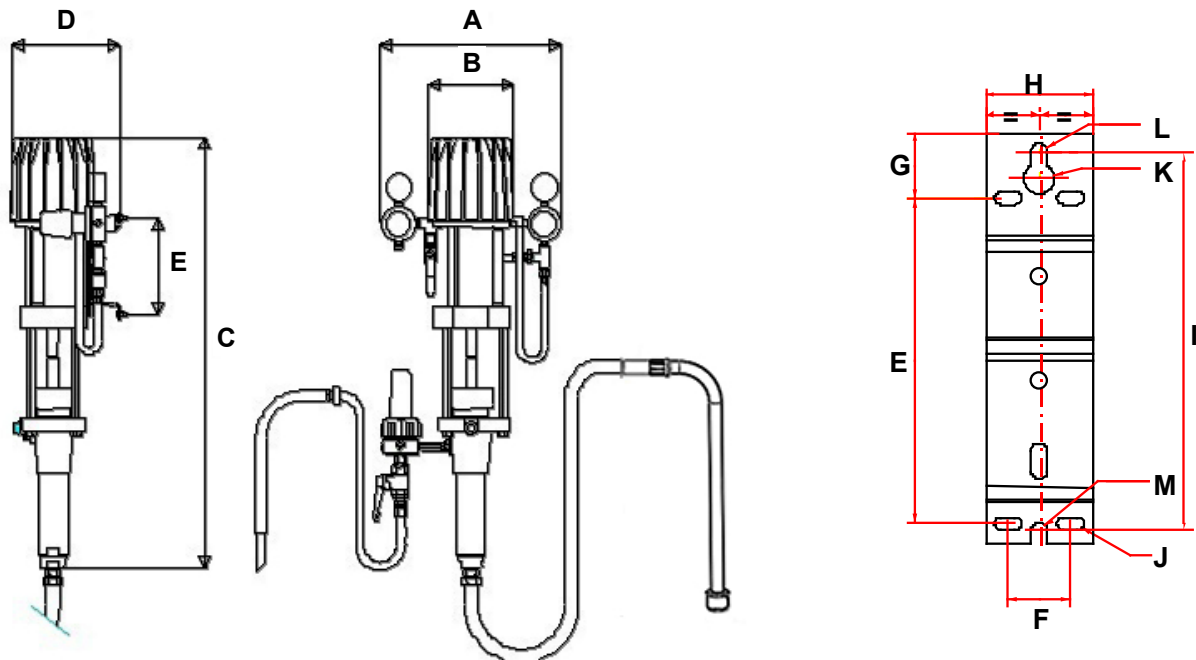

3. INSTALLATION

The pumps are designed to be installed in a spray booth.

- DESCRIPTION OF THE LABEL MARKING

Marking in accordance with the ATEX regulation



SAMES KREMLIN STAINS FRANCE	Name and address of the manufacturer
TYPE xx	Pump model
CE II 2 G	CE : European conformity : For use in explosive area II : group II 2 : class 2 G : gas Surface equipment meant to an area where explosive atmospheres due to gas, vapours, mists are liable to appear from time to time in usual operating.
P prod : xx bar / xx psi	Maximum fluid pressure at the pump outlet
P air : 6 bar / 87 psi	Air supply maximum pressure of the pump motor
Serie / Serial	Number given by SAMES KREMLIN. The 2 first numbers indicate the manufacturing year.

- TEMPERATURE CLASS

Pump, model 10C50 GT:

Temperature class	Maximum surface temperature
T3	174.8° C / 346.64°F

Pump, model 20C50 GT :

Temperature class	Maximum surface temperature
T4	111.7°C / 233.06°F

■ INSTALLATION DIAGRAM

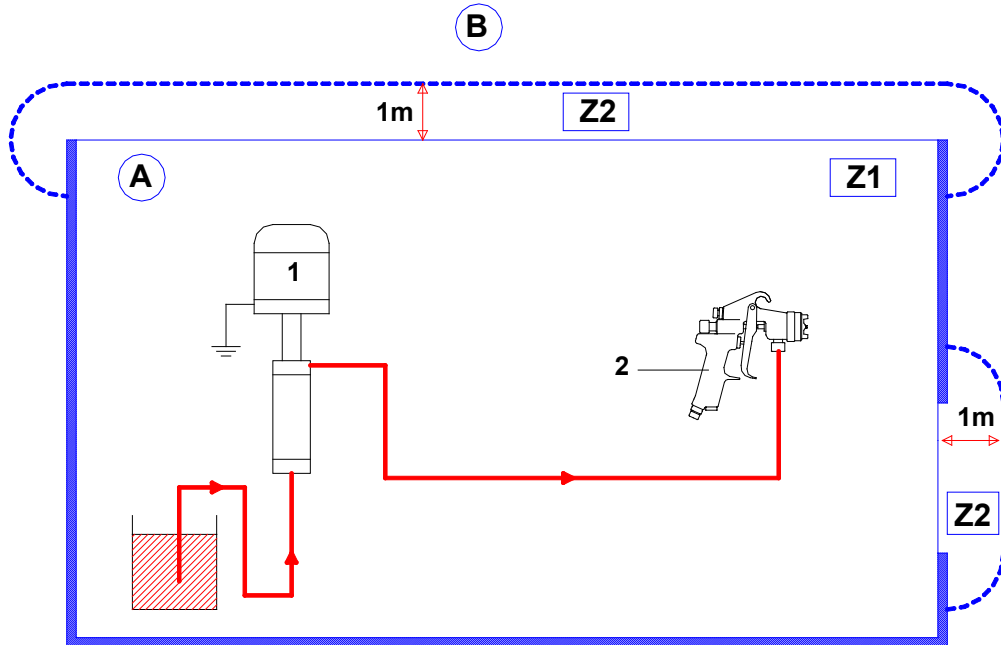

Ind.	Description
A	Explosive area area 1 (Z1) or area 2 (Z2) : spray booth
B	Non explosive area

Ind.	Description
1	Pump
2	Spray gun



The 1 m / 39.37" distance indicated in these diagrams is given for information purposes only and hold harmless to SAMES KREMLIN. The user is responsible for the extraction and conditioning of the painting area where the equipment is used, for working conditions (refer to EN 60079-10 standard). The 1 m / 39.37" distance may be modified if trials carried out by the user deem this necessary.



NB : Choose the appropriate pump to ensure that the working pressure supplied is suitable for the selected gun.